



**SUZUKI**  
**MARINE**

Parts Book  
DT15c 89-97

PREFACE

When it becomes necessary to replace parts on SUZUKI OUTBOARD MOTORS, always use SUZUKI GENUINE PARTS which have passed a strict inspection which guarantees quality and performance.

This parts catalogue covers the list of all service parts for SUZUKI DT15C '89-'97 MODEL.

INSTRUCTIONS FOR QUOYING THE CATALOGUE

1. DIMENSIONS

Dimensions of the parts in this catalogue are indicated in unit millimeters.

2. ABBREVIATIONS

Abbreviations used in this catalogue are as follows:

AR	: As required	NT	: Number of teeth
ASSY	: Assembly	OPT	: Optional
E.No.	: Engine number	OS	: Over size
F.No.	: Frame number	STD	: Standard
d	: Diameter of material	Y	: Thickness
ID	: Inside diameter	US	: Under size
OD	: Outside diameter	W	: Width
L	: Length	S,L,UL,LL	: Transom type

~123456 : Up to F.No.01502-123456

123456~ : From F.No.01502-123456

12 x 34 x 5.6 .....Figures in the description column show the dimensions of parts.

ID OD T(or W,L)

To 12345-56781 (Parts No.) : indicates that the parts number was changed to 12345-56781 and the new parts are interchangeable with the former ones but the former ones are not interchangeable with new ones.

From 12345-56781 (Parts No.) : indicates that the former and new parts are interchangeable with each other and both are usable.

3. INNER PARTS OF ASSEMBLY

Part name with a dot (.) in front as shown in the description column indicates the component of the assembly also available individually.

4. MODIFICATION NOTICE

A parts bulletin will be sent to you on all occasions when changes in parts occur, including interchangeable modifications between new parts and old ones.

5. NOTE

- 5-1. There are some different parts from those of production models among spare parts for the administrative reasons and common use of them with other models.
- 5-2. In respect of rubber hoses and vinyl tubes, please be sure to use them by cutting off according to the length mentioned on parts catalogue or what is actually required on the vehicle.
- 5-3. Note that the drawings on the illustration page are for ready reference of spare parts number, not to be used as an assembly manual.  
When assembling, use "SUZUKI SERVICE MANUAL".

6. ENGINE NUMBER

- DT15C VK '89 MODEL : 01502-901095-
- DT15C VL '90 MODEL : 01502-011001-
- DT15C VM '91 MODEL : 01502-131001-
- DT15C VN '92 MODEL : 01502-231001-
- DT15C VP '93 MODEL : 01502-351001-
- DT15C VR '94 MODEL : 01502-461001-
- DT15C VS '95 MODEL : 01502-581001-
- DT15C VT '96 MODEL : 01502-651001-
- DT15C VV '97 MODEL : 01502-751001-

FIG.1

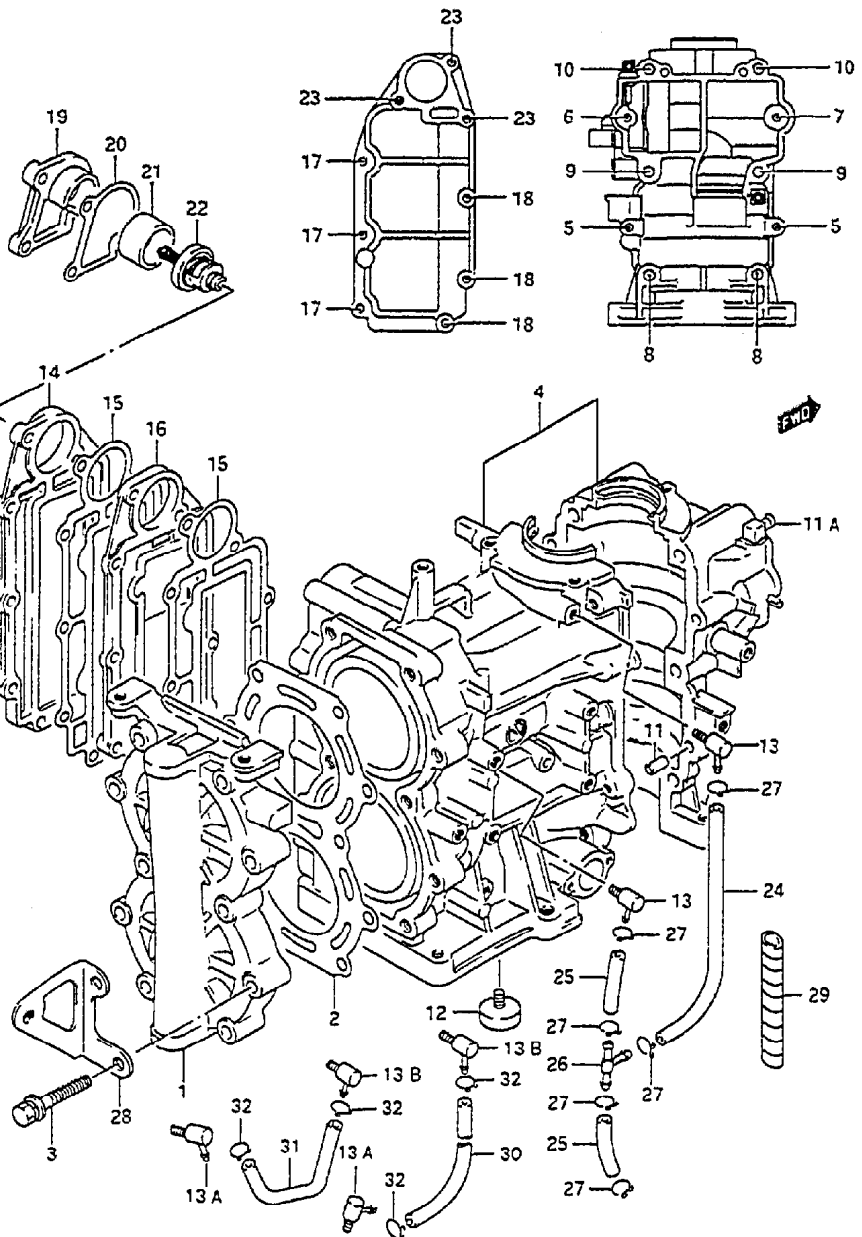

FIG.1 ( B-2) CYLINDER

REF.NO.	PART NO.	DESCRIPTION	Q'TY	REMARKS
1	11110-93990-OED	HEAD, cylinder	1	
2	11141-93950	GASKET, cylinder head	1	
3-1	09118-08116	BOLT	10	
3-2	01580-08407	BOLT	10	model:94-97
4-1	11301-89E01-OED	CYLINDER ASSY	1	
4-2	11301-89E03-OED	CYLINDER ASSY	1	461557-581336
4-3	11301-89E05-OED	CYLINDER ASSY	1	581337~
5	01550-06357	.BOLT	2	
6	01550-06457	.BOLT	1	
7	01550-06607	.BOLT	1	
8	01550-08507	.BOLT	2	
9	01550-08957	.BOLT	2	
10	09103-08258	.BOLT (8x95)	2	
11	04221-06129	.KNOCK PIN	2	
11A	16721-89E00	.NOZZLE, oil	2	
12	11130-94600	.ZINC, protection	1	
13	16710-98600	.VALVE, check	2	
13A	16725-89E02	.NOZZLE	2	581337~
13B	16710-95D10	.VALVE, check	2	581337~
14	14141-89E00-OED	COVER, exhaust	1	
15	14151-89E10	GASKET, exhaust	2	
16	14131-89E00	PLATE, exhaust	1	
17	02162-06257	BOLT	3	
18	01550-06307	BOLT	3	
19	17681-89E00-OED	COVER, thermostat	1	
20	17685-89E10	GASKET, thermostat	1	
21	17682-89E00	SPACER, thermostat	1	
22	17670-89E02	THERMOSTAT (60°C)	1	
23	01550-06407	BOLT	3	

COLOR : OED (Gray)

FIG.1

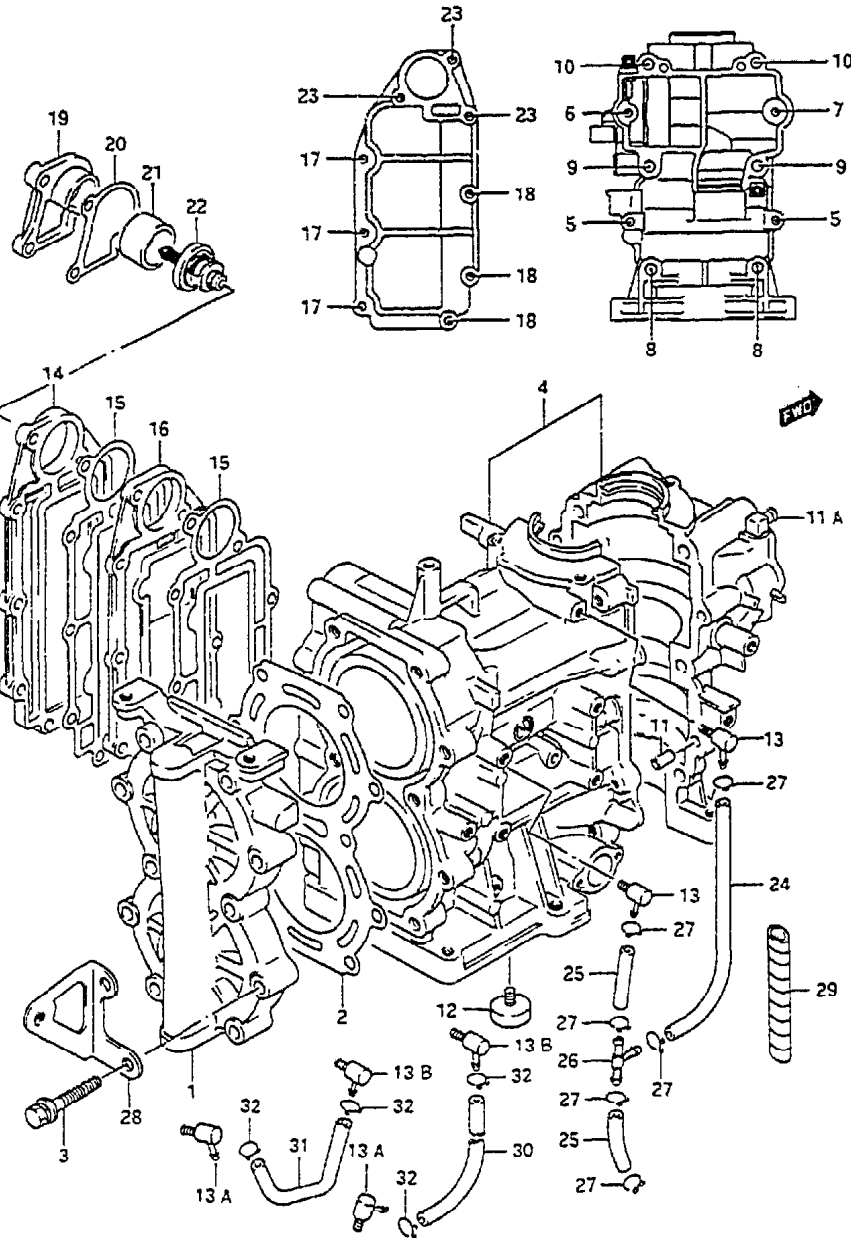

FIG.1 ( B- 3) CYLINDER

Q'TY

REF.NO.	PART NO.	DESCRIPTION	Q'TY	REMARKS
24	09355-25705-600	HOSE, lubrication	1	L:600-175 -model:94
25	09355-25705-600	HOSE, lubrication	2	L:600-33 -model:94
26-1	09367-04002	3 WAY	1	model:89-90
26-2	09367-04007	3 WAY	1	-581336
27	09401-06101	CLIP	6	-581336
28	32892-89E00-DED	BRACKET, electric parts	1	
29	16911-92E20	PROTECTOR	1	L:540-130 model:93-95
30	09355-25705-600	HOSE, lubrication	1	L:600-190 581337-
31	09355-25705-600	HOSE, lubrication	1	L:600-120 581337-
32	09401-06101	CLIP	4	581337-

FIG.2

FIG.2 ( B- 4) CRANKSHAFT

Q'TY

REMARKS

REF.NO.	PART NO.	DESCRIPTION	Q'TY	REMARKS
1-1	12110-89E00	PISTON	2	
1-2	12100-89E00-025	PISTON SET (OS:0.25)	2	OPT
1-3	12110-89E00-050	PISTON (OS:0.50)	2	OPT
2-1	12140-89E00	RING SET, piston	2	
2-2	12140-12810-050	RING SET, piston (OS:0.50)	2	OPT
3	12151-93100	PIN, piston	2	
4	09381-14001	CIRCLIP	4	
5	09263-14019	BEARING, piston pin	2	
6-1	12200-89E00	CRANKSHAFT	1	
6-2	12200-89E01	CRANKSHAFT	1	461557-
7	12161-93902	.ROD, connecting	2	
8	12211-93900	.PIN, crank	2	
9	09263-20051	.BEARING	2	
10	09160-20052	.THRUST WASHER	4	
11	12221-89E00	.CRANKSHAFT, upper	1	
12-1	12231-89E00	.WHEEL, middle upper	1	
12-2	12231-89E01	.WHEEL, middle upper	1	model:94-97
13-1	12232-89E00	.WHEEL, middle under	1	
13-2	12232-89E01	.WHEEL, middle under	1	model:94-97
14	12240-89E00	.CRANKSHAFT, under	1	
15-1	09289-30009	.OIL SEAL	1	
15-2	09289-30011	.OIL SEAL	1	461557-
16	09262-25084	.BEARING	3	
17	16321-92000	GEAR, oil pump drive	1	
18	09283-25035	OIL SEAL	1	
19	09283-20018	OIL SEAL	1	
20	09421-08001	KEY	1	
21-1	08211-20301	WASHER	1	
21-2	09181-20195	WASHER	1	model:97
22	09160-52006	WASHER	1	
23	09160-52005	WASHER	1	
24	08331-31206	CIRCLIP	1	

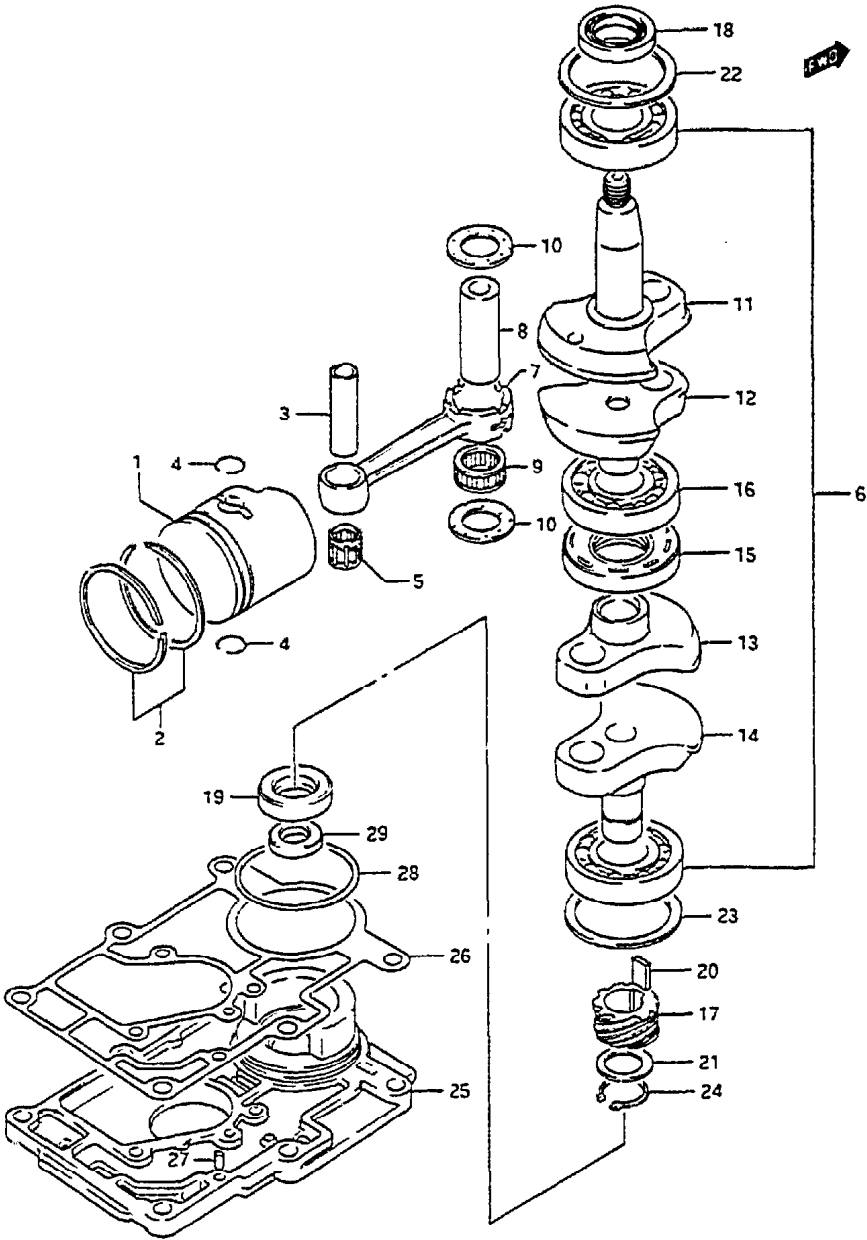

FIG.2

FIG.2 ( B- 5) CRANKSHAFT

Q'TY

REF.NO.	PART NO.	DESCRIPTION	Q'TY	REMARKS
25	11431-89E00	HOUSING, under oil seal	1	
26	11433-89E10	GASKET, under oil seal	1	
27	09202-06023	PIN	1	
28	09280-58003	O RING	1	
29	09262-12010	OIL SEAL	1	

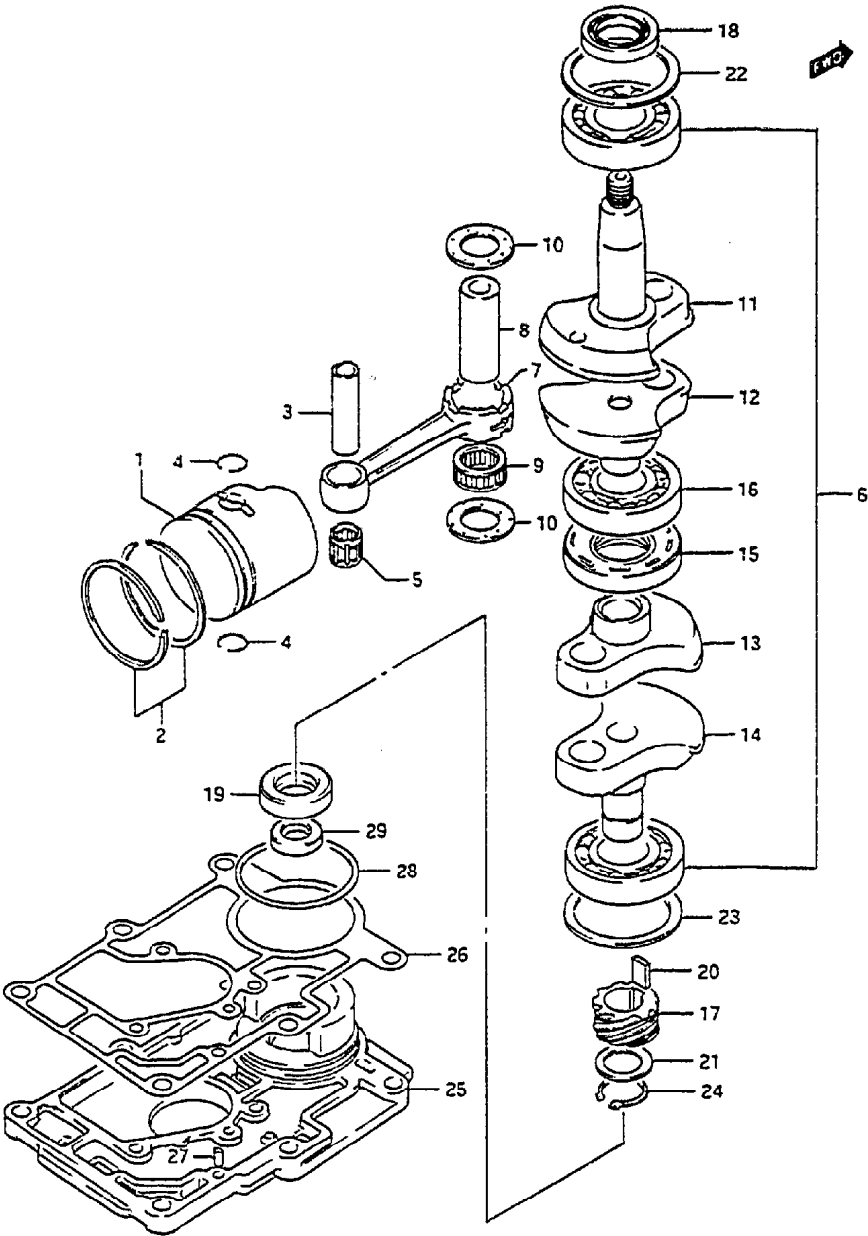
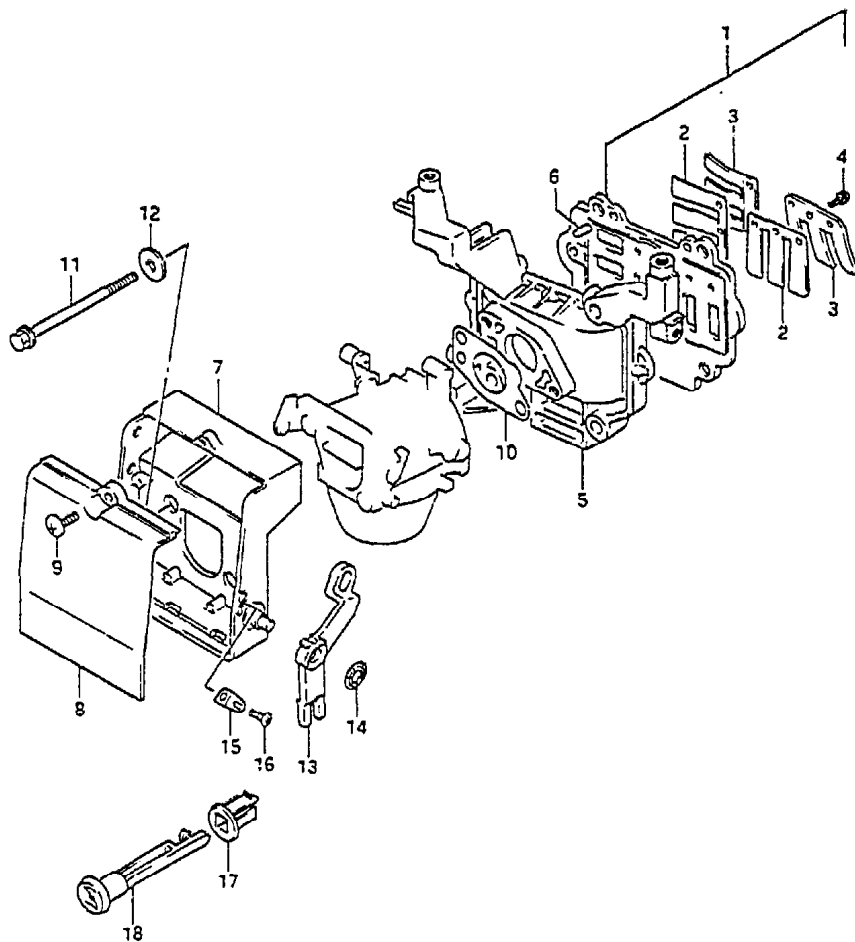

FIG.3



5

FIG.3 ( B- 6) INLET CASE

REF.NO.	PART NO.	DESCRIPTION	Q'TY	REMARKS
1	13150-89E00	REED VALVE ASSY	1	
2	13153-65010	.REED VALVE	2	
3	13152-93900	.STOPPER, reed valve	2	
4	02112-33063	.SCREW	6	
5	12481-89E00-OED	CASE, inlet	1	
6	04221-06129	PIN	2	
7	13811-89E01	CASE, silencer	1	
8	13812-89E00	COVER, silencer	1	
9	03242-05123	SCREW	1	
10	13125-91D00	GASKEY, carburetor	1	
11	01550-06907	BOLT	2	
12	09160-06066	WASHER	2	
13	13633-89E01	LEVER, choke	1	
14	09148-06008	NUT	1	
15	13694-92D00	PLATE, choke spring	1	
16	02112-04087	SCREW	1	
17	13632-93900	GROMMET, choke knob	1	
18	13631-93910	KNOB, choke lever	1	

COLOR : OED (Gray)

FIG. 4

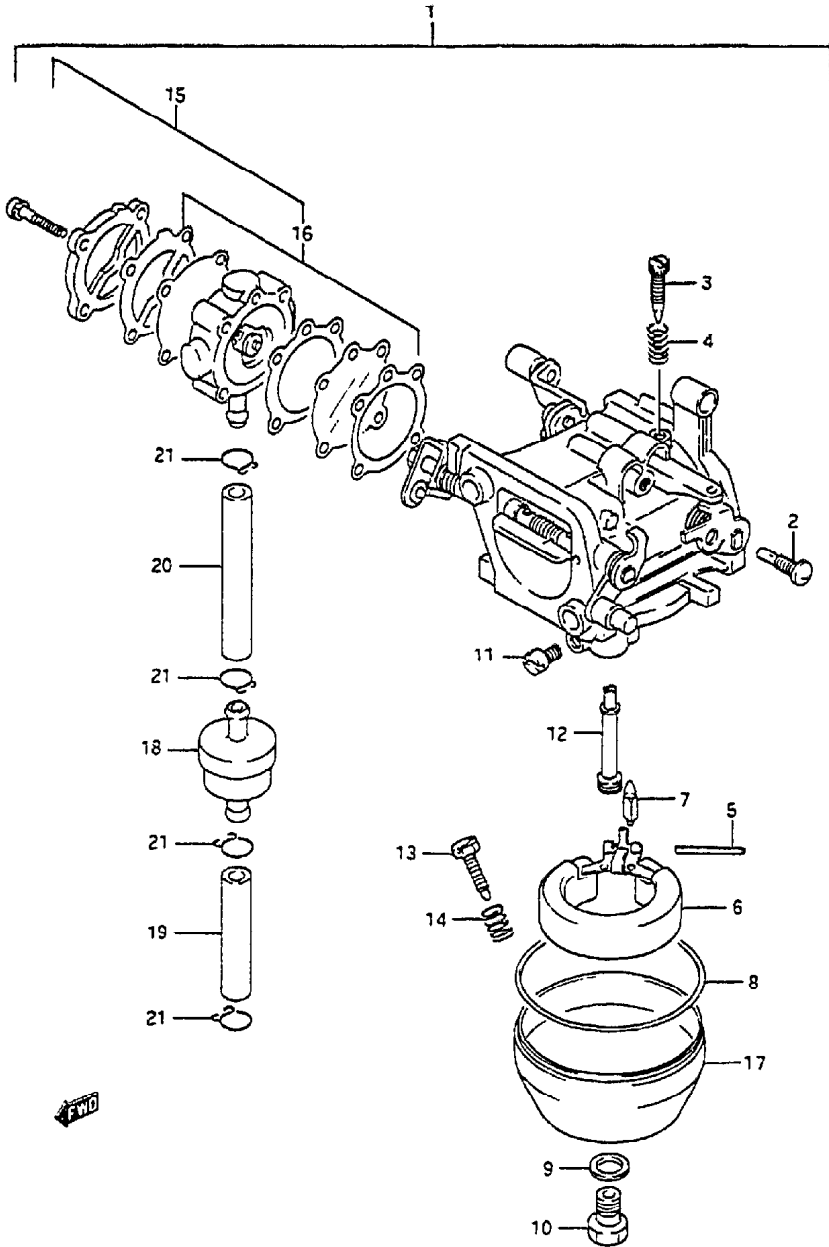

FIG. 4 ( B- 7) CARBURETOR

REF. NO.	PART NO.	DESCRIPTION	Q'TY	REMARKS
1	13200-89E10	CARBURETOR ASSY	1	+13200-89E03
2	09492-65002	.JET, pilot (65)	1	
3	13616-93900	.SCREW, pilot	1	
4	13268-96111	.SPRING, throttle	1	
5	13254-98100	.PIN, float	1	
6	13250-98110	.FLOAT	1	
7	13371-98100	.VALVE, needle	1	
8	13251-98100	.GASKET, float chamber	1	
9	13343-98100	.GASKET	1	
10	13613-98100	.BOLT	1	
11-1	09491-29002	.JET, main (145)	1	-model:91
11-2	09491-25014	.JET, main (125)	1	
12	13235-89E01	.NOZZLE	1	
13	13279-90000	.ADJUSTER	1	
14	13268-96111	.SPRING	1	
15	15100-93911	.PUMP ASSY	1	+15100-93910
16	15170-93911	.DIAPHRAGM SET	1	+15170-93910
17	13245-98110	.CHAMBER ASSY, FLOAT	1	
18	15410-98500	FILTER, fuel	1	
19	09352-50903-600	HOSE (CONNec TO FILTER)	1	L:600+45
20	09352-50903-600	HOSE (FILTER TO PUMP)	1	L:600+70
21	09401-08410	CLIP	4	

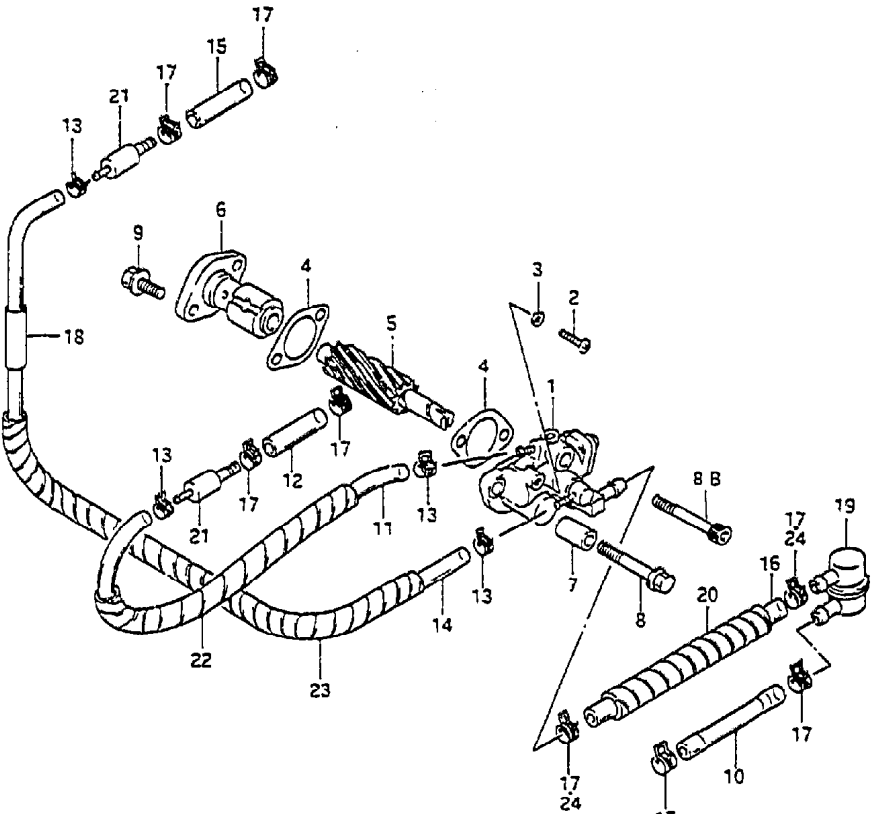

FIG. 5

FIG. 5 ( 8- 8) OIL PUMP

Q'TY

REF.NO.	PART NO.	DESCRIPTION	REMARKS
1	16100-89E10	PUMP ASSY, oil	1
2	16191-89E00	.SCREW, bleed	1
3	16192-94400	.GASKET, bleed	1
4	16731-92D10	GASKET, oil pump	2
5	16331-89E00	GEAR, oil pump driven	1
6	16340-92000	RETAINER, oil pump	1
7	09180-05030	SPACER, oil pump	2 -model:96
8	01580-05357	BOLT	2 -model:96
8B	07130-05167	BOLT	2 model:97
9	02162-05167	BOLT	2
10	16921-89E00	HOSE, oil pump inlet No.1	1
11-1	09351-25703-600	HOSE (PUMP TO VALVE)	1 L:600+380,model:89,90
11-2	09355-25705-600	HOSE (PUMP TO VALVE)	1 L:600+380,model:91-97
12	09351-50803-600	HOSE (VALVE TO CYL)	1 L:600+45
13	09401-06405	CLIP	4
14-1	09351-25703-600	HOSE (PUMP TO VALVE)	1 L:600+220,model:89,90
14-2	09355-25705-600	HOSE (PUMP TO VALVE)	1 L:600+220,model:91-97
15	09351-50803-600	HOSE (VALVE TO CYL)	1 L:600+45
16-1	09351-50803-600	HOSE, oil pump inlet No.2	1 L:600+125,model:89,90
16-2	09352-50903-600	HOSE, oil pump inlet No.2	1 L:600+125,model:91-97
17-1	09401-08409	CLIP	8 model:89,90
17-2	09401-08409	CLIP	6 model:91-97
18	09351-80902-600	PROTECTOR, hose	1 L:600+35
19	16810-92000	FILTER, oil	1
20	16911-92E20	PROTECTOR	1 L:540+110
21	16710-92E00	VALVE, check	2
22	16911-92E20	PROTECTOR	1 L:540+180
23	16911-92E20	PROTECTOR	1 L:540+240
24	09401-08411	CLIP	2 model:91-97



FWP

FIG.6

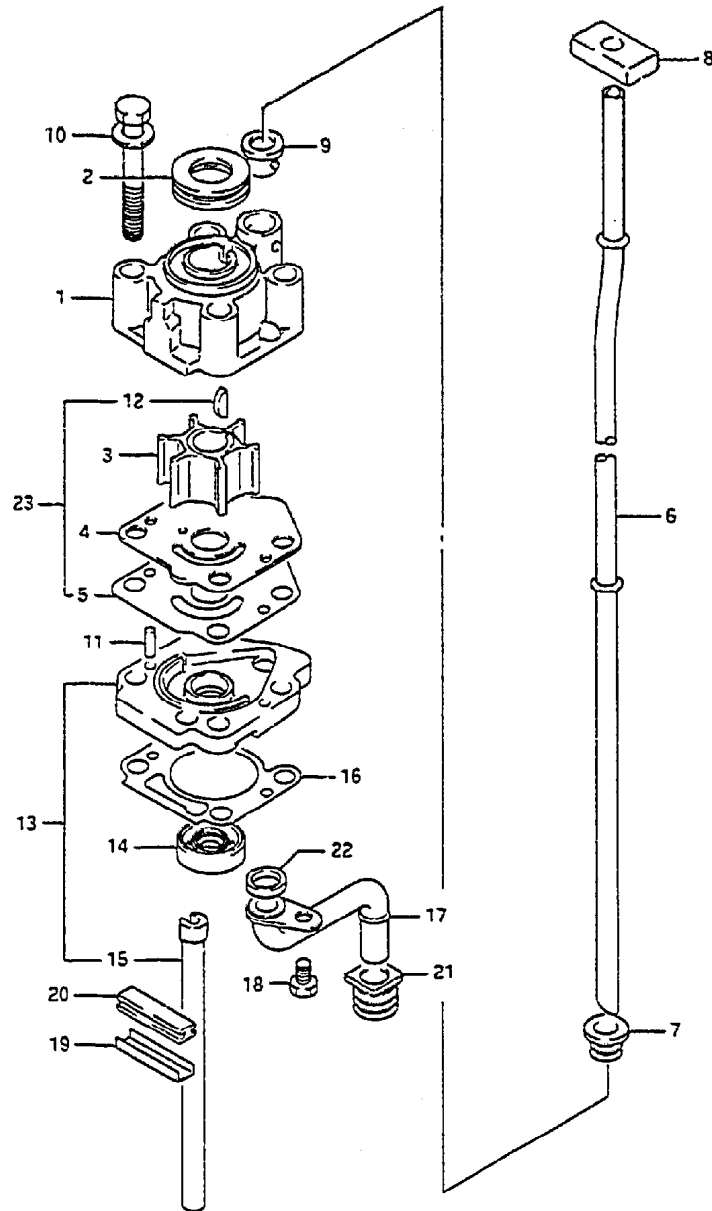

B

FIG.6 ( B- 9) WATER PUMP

REF.NO.	PART NO.	DESCRIPTION	Q'TY	REMARKS
1	17411-93901	CASE, water pump	1	
2	17417-93910	GROMMET, pump case	1	
3	17461-93902	IMPELLER, water pump	1	
4	17471-93902	PANEL, pump case under	1	
5	17472-93910	GASKET, pump case under	1	
6-1	17561-89E10	TUBE, water (S)	1	
6-2	17561-89E11	TUBE, water (S)	1	model:96,97
6-3	17561-89E00	TUBE, water (L)	1	
6-4	17561-89E01	TUBE, water (L)	1	model:96,97
7	17562-93900	GROMMET	1	
8	17563-89E01	RUBBER, water tube upper	1	
9	17564-93900	BUSH, water pump case	1	
10	09116-08089	BOLT	4	
11	09202-04014	PIN	2	
12	17462-93990	KEY	1	
13	17450-93931	HOUSING, water inlet	1	
14	09289-12003	.OIL SEAL	1	
15-1	17453-93900	.DRAIN, water inlet	1	
15-2	17453-93901	.DRAIN, water inlet	1	model:97
16	17452-93910	GASKET, water inlet HSG	1	
17	17520-93902	TUBE, water inlet	1	
18	09100-06106	BOLT	1	
19	55331-93901	CORE, exhaust seal	1	
20-1	55332-93900	RUBBER, exhaust seal	1	
20-2	55332-92D00	RUBBER, exhaust seal	1	model:95-97
21	09308-10010	GROMMET	1	
22	09308-10011	GROMMET	1	
23	17400-93950	KIT, water pump repair	1	OPT

FIG.7

FIG.7 ( B-10) THROTTLE CONTROL

Q'TY

REF.NO.	PART NO.	DESCRIPTION	Q'TY	REMARKS
1	19121-89E00	LEVER, throttle control	1	
2	19131-95502	CONNECTOR, throttle rod	1	
3	19135-89E00	ROD, throttle	1	
4	09140-05005	NUT	2	
5	19141-89E00	CAM, throttle	1	
6-1	09160-06036	WASHER	2	
6-2	09160-06084	WASHER	2	model:97
7	09180-06211	SPACER	1	
8	01550-06407	BOLT	1	
9	19148-89E00	DRUM, throttle	1	
10	02162-06127	BOLT	2	
11	19184-89E00	BRACKET, throttle cable	1	
12	19185-89E01	SPRING, throttle lever	1	
13	19831-89E00	ROD, slow adjuster	1	
14	19841-89E00	KNOB, slow adjuster	1	
15	09204-01006	COTTER PIN	1	
16	19845-89E00	NOTCH, slow adjust	1	
17	09160-10082	WASHER	1	
18	09161-10007	WASHER	1	
19	02112-05107	SCREW	1	
20	19171-89E00	ROD, stator	1	
21	09140-05005	NUT	2	
22	09119-05010	PIVOT, ball	1	
23	19131-95502	CONNECTOR	2	
24	19211-89E00	LEVER, spark advance	1	
25	19231-89E01	SPRING, spark advance lever	1	
26	19147-89E00	KNOTCH, throttle drum	1	
27	09118-06038	BOLT	1	

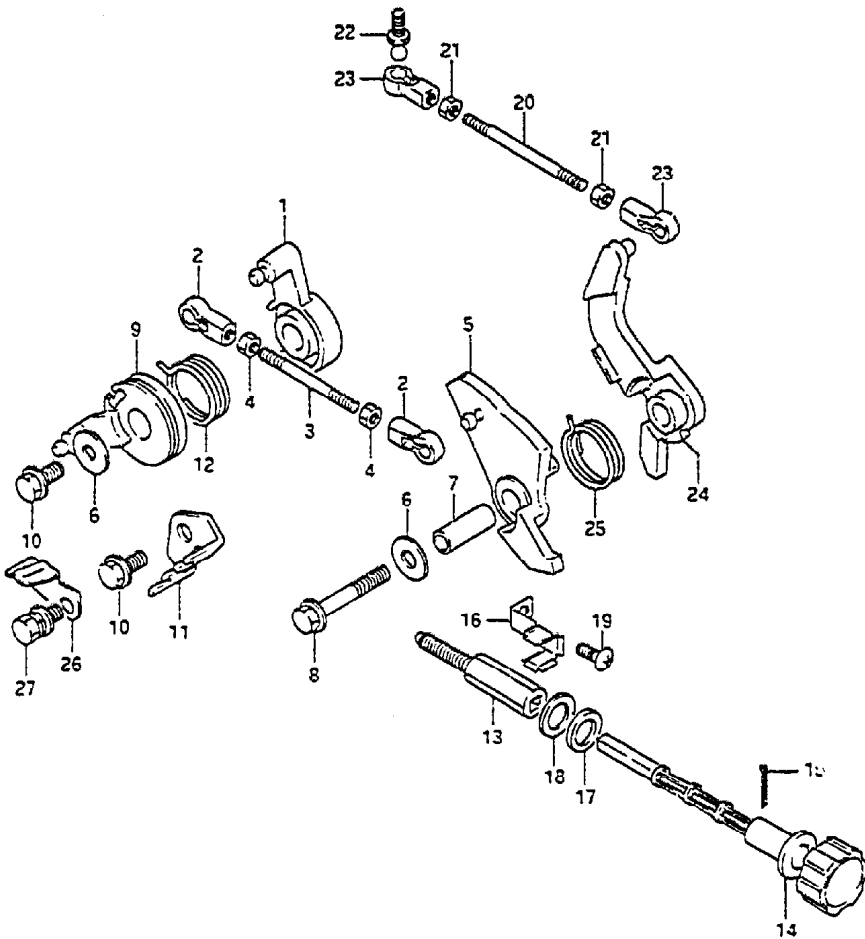

REV.

FIG. 8

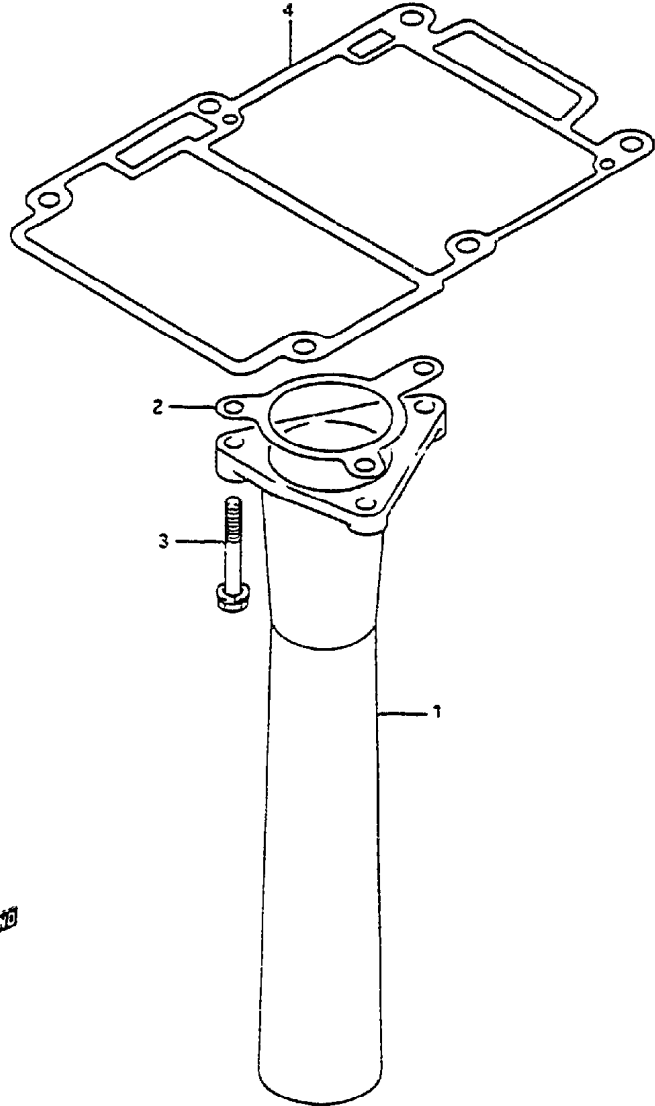
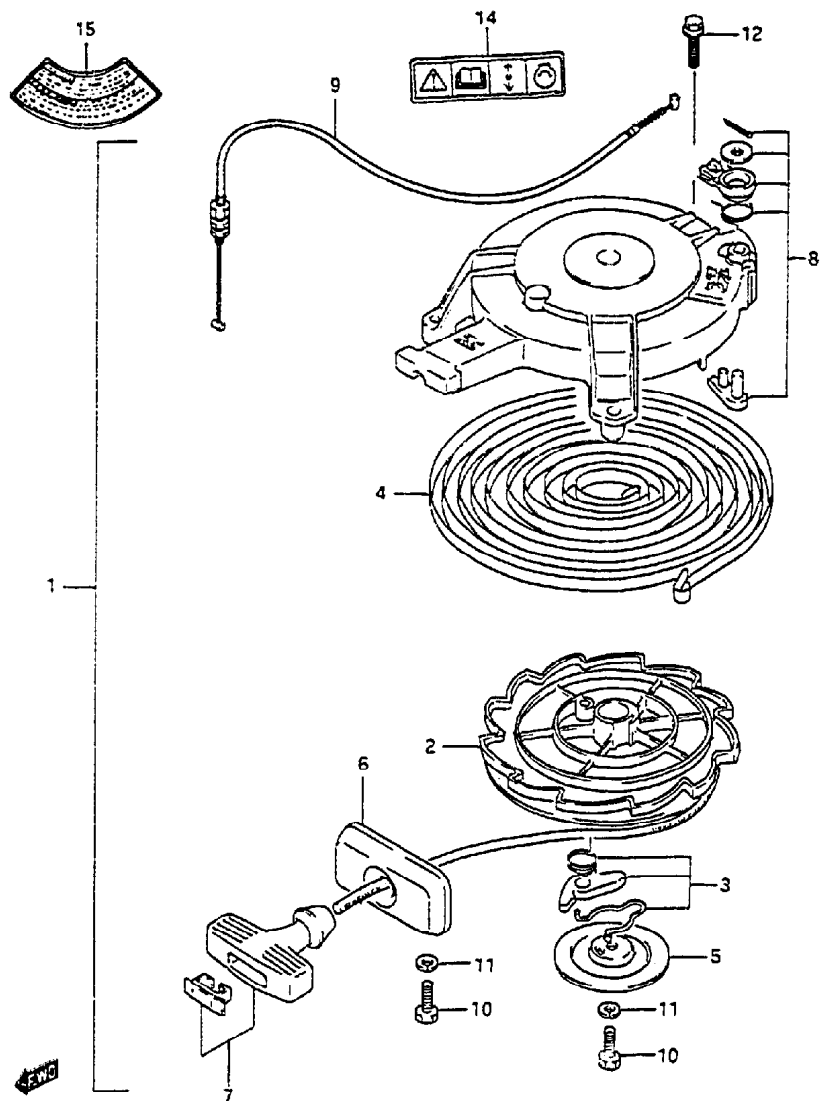

FIG. 8 ( B-11) EXHAUST TUBE

REF. NO.	PART NO.	DESCRIPTION	Q'TY	REMARKS
1	14211-89E00	TUBE, exhaust	1	
2	14213-89E10	GASKET, exhaust tube (JA)	1	+14213-89E00
3	09117-06037	BOLT (6x35)	3	
4	52113-89E10	GASKET, drive shaft HSG	1	+52113-89E00

← 10

FIG. 9



11

FIG. 9 ( B-12) STARTER

REF. NO.	PART NCL	DESCRIPTION	Q'TY	REMARKS
1	18100-89E01	STARTER, recoil	1	
2	18120-93900	.DRUM, shave	1	
3	18130-93900	.RACHEY SET	1	
4	18142-93900	.SPRING	1	
5	18151-93900	.PLATE	1	
6	18181-93900	.GUIDE, rope	1	
7	18210-93002	.GRIP ASSY	1	
8	18280-93900	.NSI SET	1	
9	18292-89E00	.CABLE, NSI	1	
10	01500-06167	.BOLT	1	
11	08321-01067	.WASHER	1	
12	09128-06072	BOLT	3	
14	69711-93E00	LABEL, caution S.I.G.P	1	
15	61582-98110	MARK, warning	1	

FIG.10

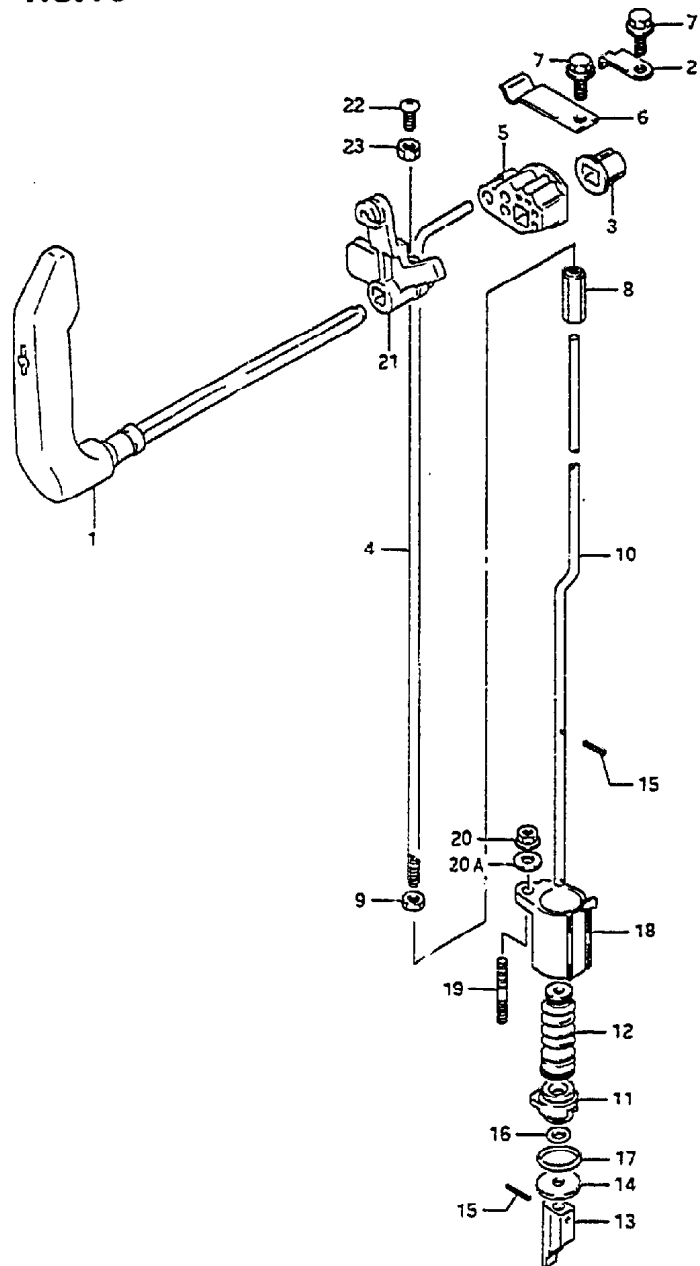

FIG.10 ( B-13) CLUTCH

REF.NO.	PART NO.	DESCRIPTION	Q'TY	REMARKS
1	21110-89E00	LEVER, clutch	1	
2	21126-92D00	HOLDER, clutch shaft	1	
3	21220-93900	BUSH, clutch lever	1	
4	23111-93901	ROD, clutch	1	
5	23211-93900	ARM, clutch rod	1	
6	23213-93900	SPRING, notch plate	1	
7	09103-06120	BOLT	2	
8	23311-94300	TURN BUCKLE, clutch rod	1	
9	09140-06020	NUT	1	
10-1	25111-93910	ROD, shift (S)	1	
10-2	25111-93900	ROD, shift (L)	1	
11	25211-93901	GUIDE, shift rod	1	
12	25222-93901	BOOT, shift rod	1	
13-1	25311-93910	CAM, shift	1	
13-2	25311-93E00	CAM, shift	1	model:97
14	09160-05005	WASHER	1	
15	09205-02006	SPRING PIN	2	
16	09280-05005	O RING	1	
17	09280-19006	O RING	1	
18	25205-93901	COLLAR, shift rod	1	
19	09108-05007	BOLT	1	
20-1	09159-05015	NUT	1	
20-2	09140-05005	NUT	1	model:95-97
20A	09160-05029	WASHER	1	
21	19851-89E00	LEVER, NSI	1	
22	02112-05127	SCREW	1	
23	08310-00057	NUT	1	

FIG. 11

FIG.11 ( C- 2) STARTING MOTOR

Q'TY

REMARKS

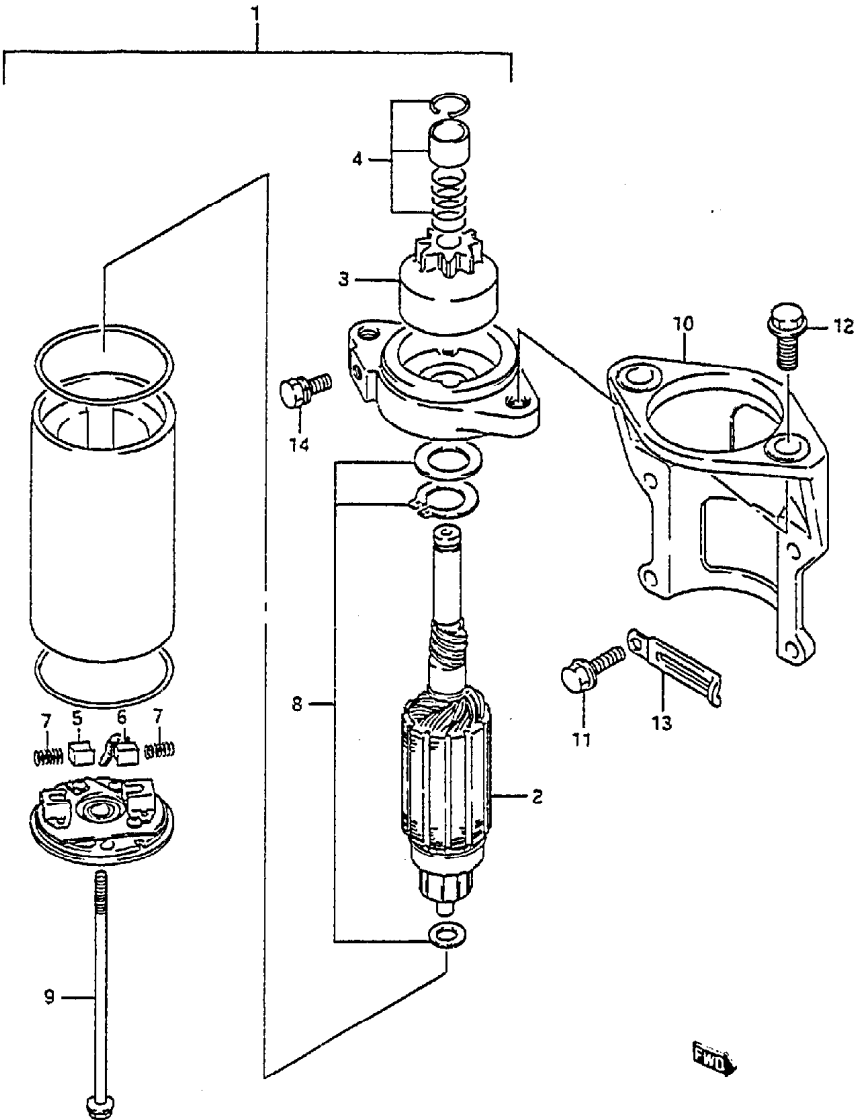

REF.NO.	PART NO.	DESCRIPTION	Q'TY	REMARKS
1	31100-89E01	MOTOR, starting	1	
2	31310-92D10	.ARMATURE, starter	1	
3-1	31320-92D10	.PINION ASSY	1	
3-2	31320-89E00	.PINION ASSY	1	232153~
4-1	31312-89E00	.STOPPER SET, pinion	1	
4-2	31312-92D10	.STOPPER SET, pinion	1	model:95-97
5	31131-89E00	.BRUSH (+)	1	
6	31132-89E00	.BRUSH (-)	1	
7	31135-92D10	.SPRING	2	
8	31360-92D10	.WASHER KIT	1	
9	31281-92D10	.BOLT, starter housing	2	
10	31911-89E00-OED	BRACKET, starter	1	
11-1	01517-06202	BOLT	4	model:89
11-2	01560-06207	BOLT	4	model:90-94
11-3	01550-06207	BOLT	4	model:95-97
12	01550-08207	BOLT	2	
13-1	09404-06413	CLAMP	1	L:70
13-2	09404-08206	CLAMP	1	L:82
14	01580-06167	BOLT	1	

COLOR : OED (Gray)

FWD

FIG. 12

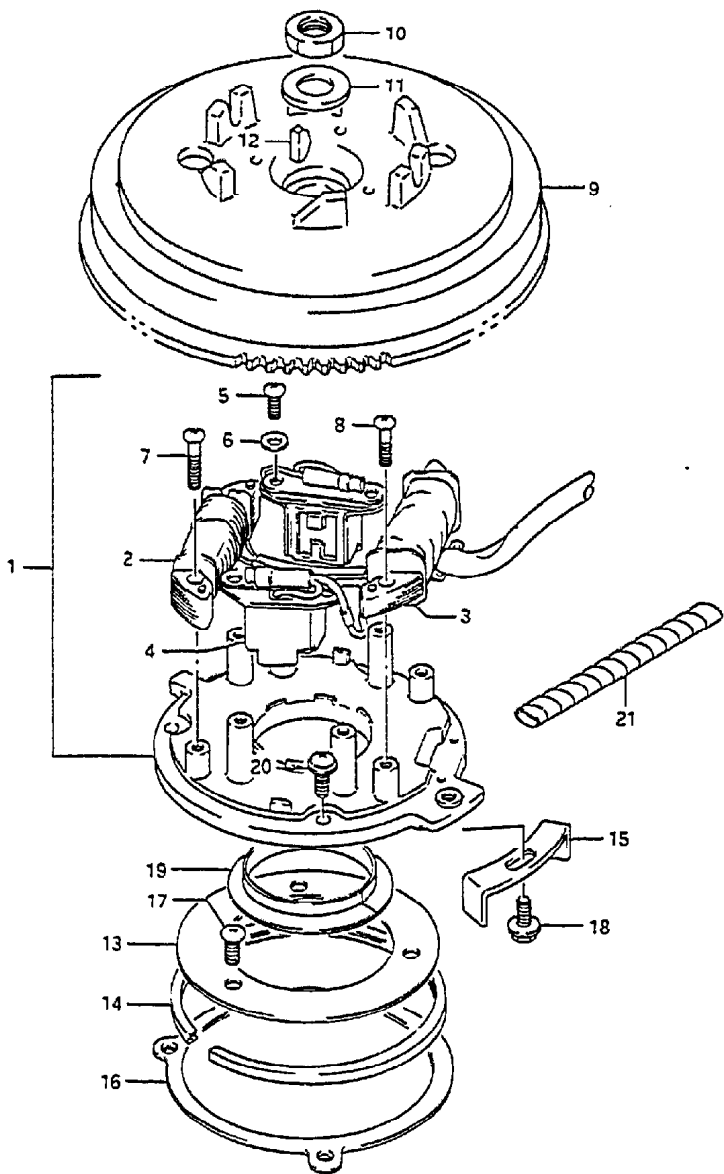

14

FIG.12 ( C- 3) MAGNETO

REF.NO.	PART NO.	DESCRIPTION	Q'TY	REMARKS
1	32101-89E10	STATOR	1	
2-1	32120-89E00	.COIL, lighting	1	electric starter
2-2	32120-89E10	.COIL, lighting	1	manual starter
3	32140-89E00	.COIL, IGN primary	1	
4	32160-89E00	.SENSOR, IGN timing	1	
5	02112-05127	.SCREW	4	
6	08321-01057	.WASHER	8	
7	02112-05303	.SCREW	2	
8	02112-05257	.SCREW	2	
9	32102-89E00	FLYWHEEL	1	
10	09140-14008	NUY	1	
11	09160-14052	WASHER	1	
12	09420-04008	KEY	1	
13	19151-89E00	RETAINER, stator	1	
14	19161-92D00	SPACER, stator	1	
15	19172-89E02	STOPPER, stator	1	
16	19181-92D00	FRICITION, stator	1	
17-1	09125-06063	SCREW	3	
17-2	02112-06107	SCREW	3	model:95-97
18	02162-05107	BOLT	1	
19	32390-89E00	RETAINER, magneto stator	1	
20	02142-05103	SCREW	3	
21	38423-95510	TUBE, 150	1	manual starter L:150+100



FIG.13

FIG.13 ( C- 4) IGNITION

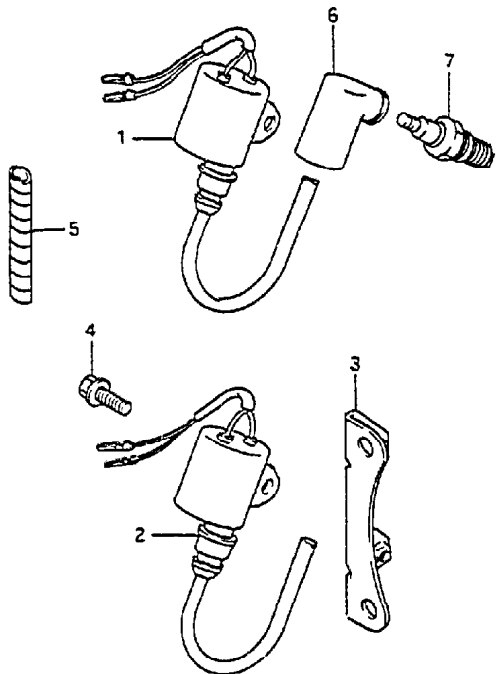
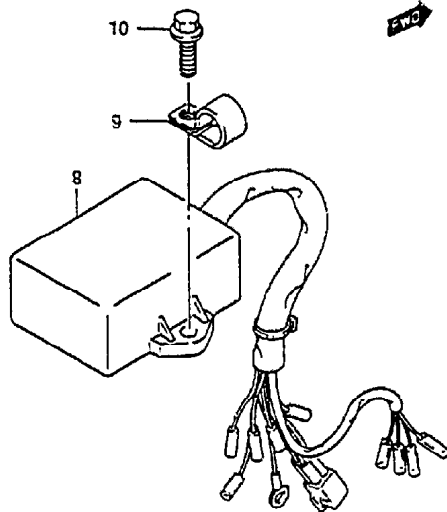

REF.NO.	PART NO.	DESCRIPTION	Q'TY	REMARKS
1	33410-89E00	COIL, ignition	1	
2	33420-89E00	COIL, ignition	1	
3	33445-89E00	BRACKET, ignition coil	1	
4	01550-06167	BOLT	2	
5	38423-95510	TUBE, L:150	1	L:150+50
6-1	33510-95520	CAP, plug	2	+33510-95510
6-2	33510-98600	CAP, plug	2	model:94-97
7-1	09482-00269	PLUG, spark (B7HS)	2	
7-2	09482-00277	PLUG, spark (BR7HS)	2	model:93-97
8-1	32900-89E00	CDI UNIT	1	-903059
8-2	32900-89E01	CDI UNIT	1	903060-
9	09403-14204	CLAMP	1	
10	01550-06207	BOLT	2	

FIG. 14

FIG. 14 ( C- 5) ELECTRICAL (1)

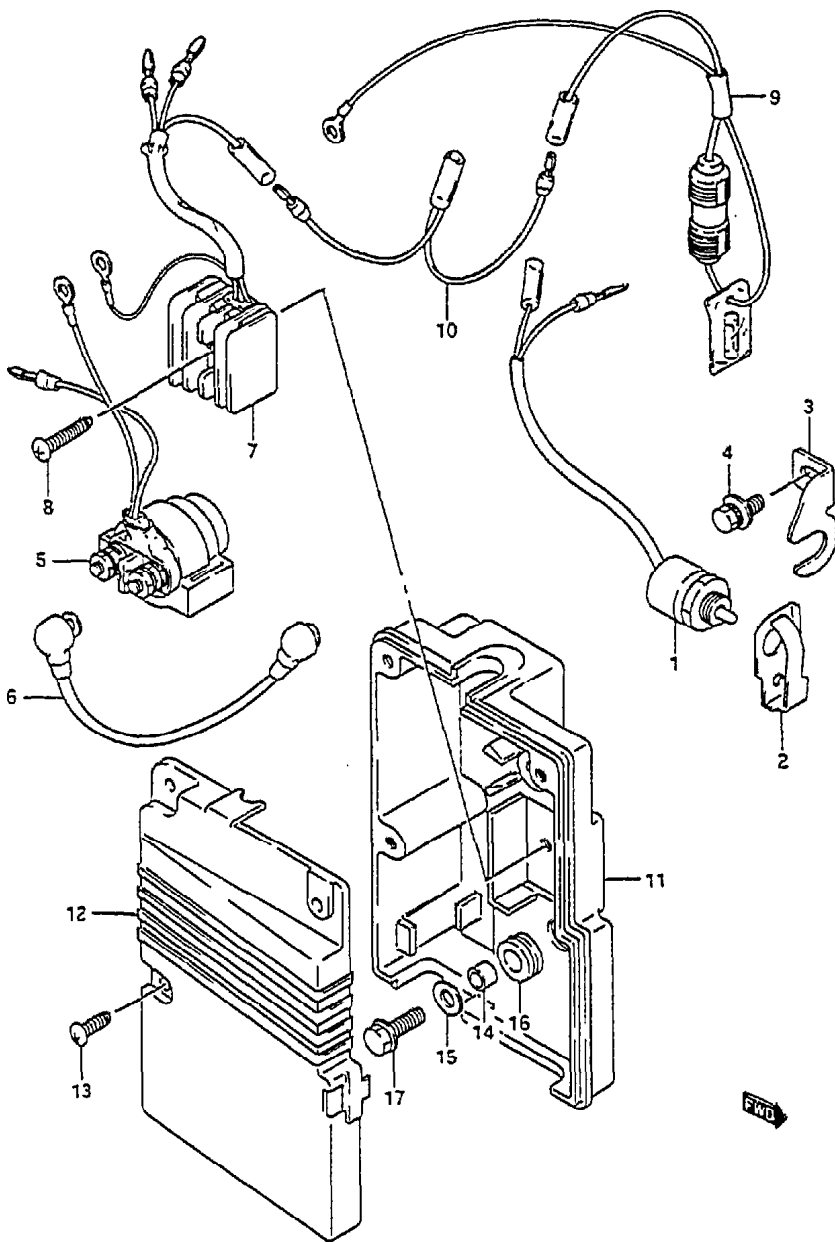

REF.NO.	PART NO.	DESCRIPTION	Q'TY	REMARKS
1-1	37721-89E01	SWITCH, neutral start	1	electric starter
1-2	37721-89E02	SWITCH, neutral	1	model:97
2	37725-94302	ACTUATOR, neutral SW	1	electric starter
3	37726-94402	BRACKET, neutral SW	1	electric starter
4	09118-06038	BOLT	1	electric starter
5	31800-94401	RELAY, starter	1	electric starter
6-1	33820-89E00	CABLE, plus TERM to relay	1	electric starter
6-2	33820-89E01	CABLE, plus TERM to relay	1	model:94-97
7	32800-95001	RECTIFIER	1	electric starter
8	03212-05253	SCREW	1	electric starter
9	36740-89E00	CASE, fuse	1	electric starter
10	36610-92000	HARNESS, wiring	1	electric starter
11	32890-89E00	HOLDER, electric parts	1	
12	32891-89E00	COVER, electric parts	1	
13	03212-05163	SCREW	4	
14-1	09180-06187	SPACER	3	
14-2	09180-06248	SPACER	3	model:97
15	09160-06052	WASHER	3	
16	09320-08001	CUSHION	3	
17	01550-06207	BOLT	3	

FIG. 15

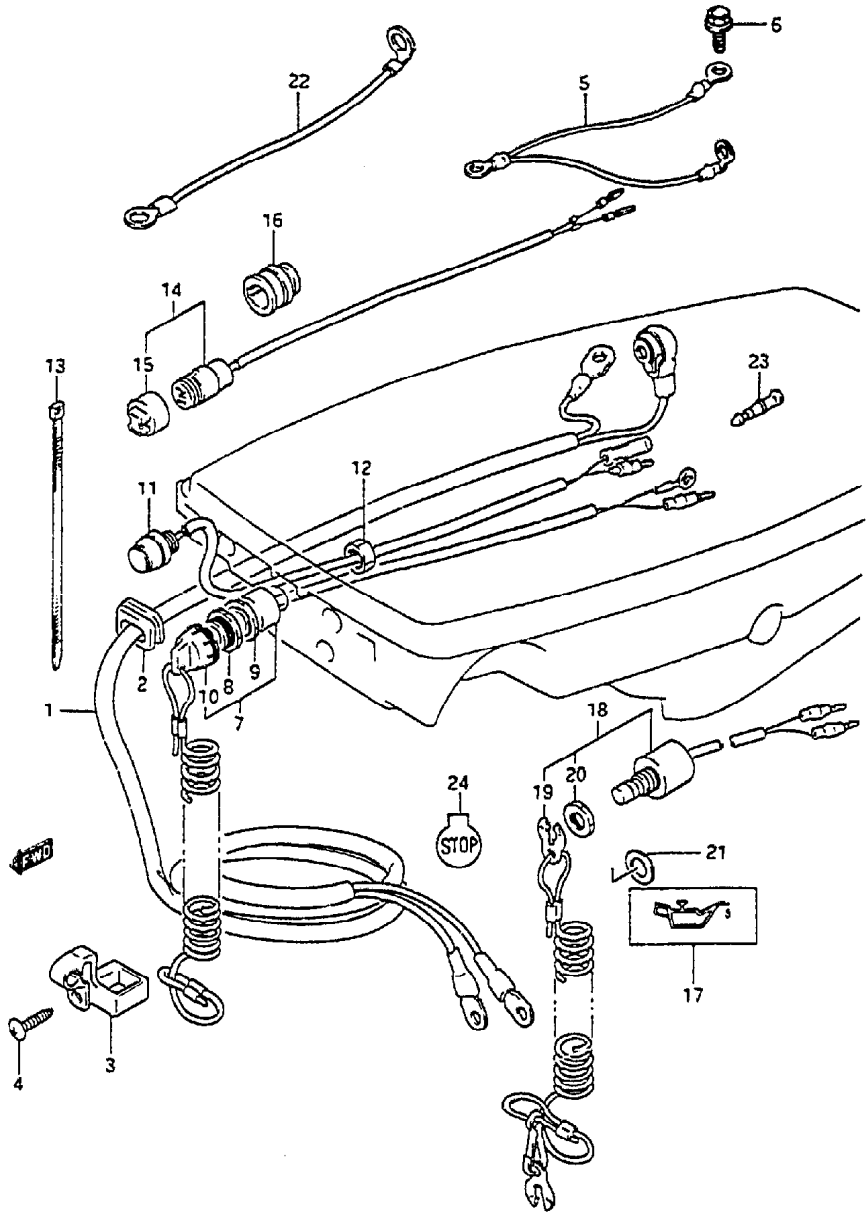

FIG.15 ( C- 6) ELECTRICAL (2)

Q'TY

REF.NO.	PART NO.	DESCRIPTION	Q'TY	REMARKS
1-1	33810-89E00	CABLE, starter	1	electric starter
1-2	33810-89E01	CABLE, starter	1	electric starter 232021-
2	33811-96300	GROMMET, starter cable	1	electric starter
3	33816-96300	CLAMP	1	electric starter
4	03242-06253	SCREW	1	electric starter
5	36895-95300	LEAD, ground	1	
6	09103-06049	BOLT (6x12)	1	
7	37830-89X50	SWITCH, emergency	1	-model:92
8	37825-89E00	.NUT, upper	1	-model:92
9	37826-89E00	.NUT, lower	1	-model:92
10	37823-94400	.CAP/ROPE	1	-model:92
11	37161-89E12	SWITCH, start	1	electric starter
12	09159-14014	NUT	1	electric starter
13-1	36632-95501	CLAMP	1	manual starter
13-2	09407-25402	CLAMP	1	model:97
14	39601-95D00	RECEPTACLE, lighting	1	manual starter
15	36634-93910	.CAP	1	manual starter
16	39603-92D00	GROMMET	1	manual starter
17	36367-95D10-064	LABEL, oil level	1	
18	37830-89E00	SWITCH ASSY, emergency/stop	1	model:93-97
19	37823-92E00	.PLATE, lock	1	model:93-97
20	37826-92E00	.NUT	1	model:93-97
21	09160-12067	WASHER	1	model:93-97
22	37801-98300	LEAD, EMER & stop SW	1	
23	36615-96300	TERMINAL, resin	1	
24	37835-95D00	LABEL, stop	1	

COLOR : 064 (White)

FIG.16

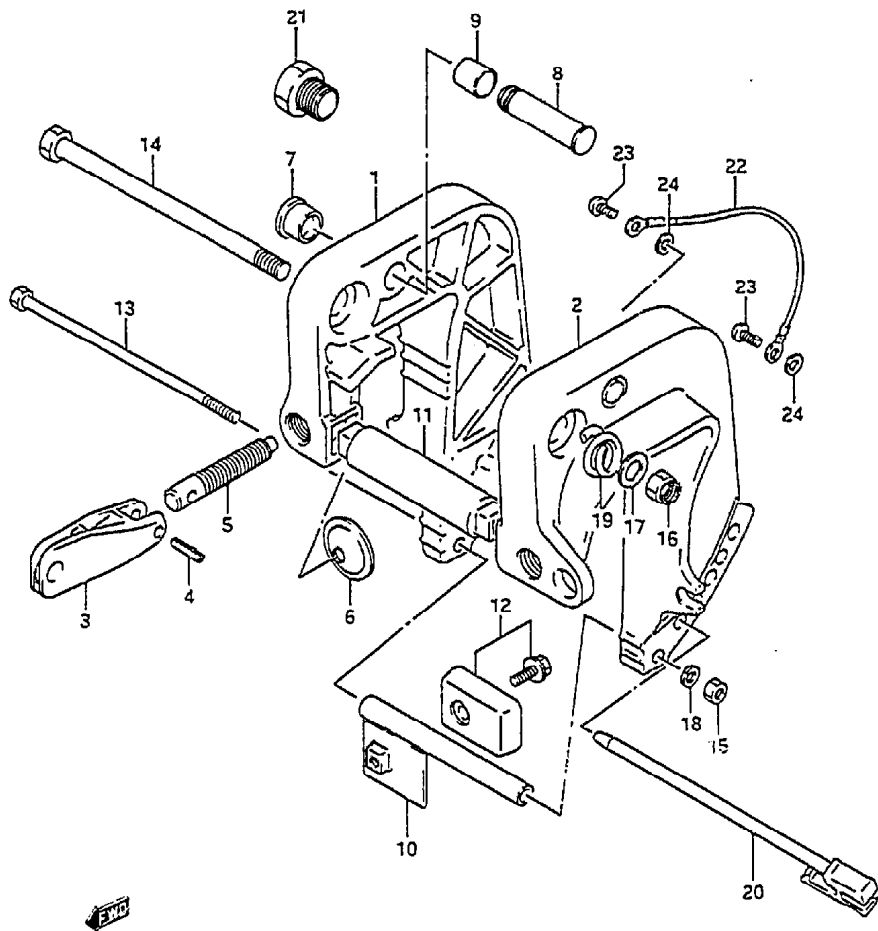

18

FIG.16 ( D- 2) CLAMP BRACKET

REF.NO.	PART NO.	DESCRIPTION	Q'TY	REMARKS
1	41110-89E20-OED	BRACKET, clamp STBD	1	
2	41120-89E20-OED	BRACKET, clamp PORT	1	
3	41212-93000-OED	HANDLE, clamp	2	
4	09205-06007	SPRING PIN	2	
5-1	41211-93910	SCREW, clamp (L:78)	2	
5-2	41211-93920	SCREW, clamp (L:90)	2	OPT
5-3	41211-93900	SCREW, clamp (L:68)	2	OPT
6	41213-98100	PLATE, clamp	2	
7	41221-96301	KNOB, tilt stopper	1	
8	41222-93910	PIN, tilt stopper	1	
9	09303-14003	BUSH	1	
10	41310-93900	ROD, clamp bracket lower	1	
11	41411-92D01	GRIP, carrier	1	
12	55320-95310	ZINC, protection	1	
13	09100-06125	BOLT	1	
14	09100-10199	BOLT	1	
15	09140-06020	NUT	1	
16	09159-10050	NUT	1	
17	09160-10082	WASHER	1	
18	09162-06006	WASHER	1	
19	09440-22008	SPRING	1	
20	45420-92D02	PIN, tilt lock	1	
21	41141-94300	ATTACHMENT, steering cable	1	OPT,L:40
22	36894-95201	LEAD	1	
23	09125-05050	SCREW	2	
24	09161-05114	WASHER	2	

COLOR : OED (Gray)

Refer to FIG.16A(D-3) for model:96,97

FIG.16A

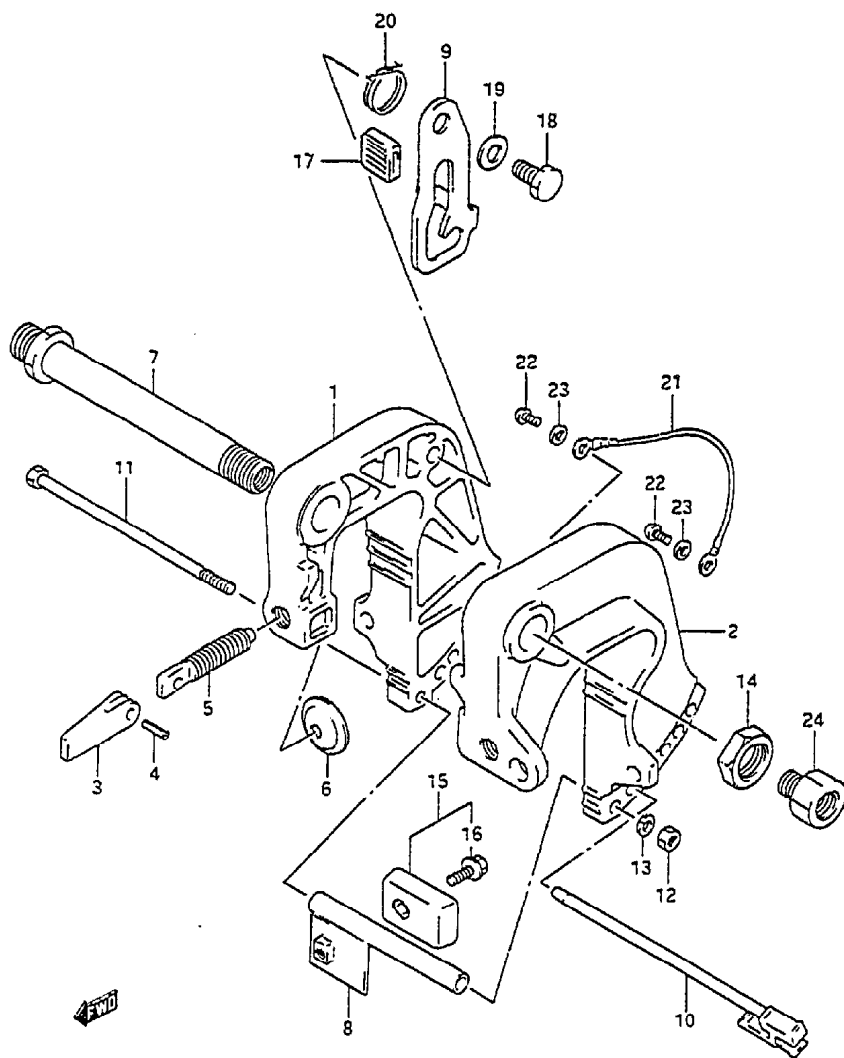

FIG.16A( D-3) CLAMP BRACKET (MODEL:96,97)

REF.NO.	PART NO.	DESCRIPTION	Q'TY	REMARKS
1	41111-89E50-DED	BRACKET, clamp STBD	1	
2	41121-89E50-DED	BRACKET, clamp PORT	1	
3	41212-98601	HANDLE, clamp	2	
4	09205-05013	PIN, spring	2	
5	41211-89E00	SCREW, clamp	2	
6	41213-98100	PLATE, clamp	2	
7	41130-89E00	SHAFT, clamp BRKT	1	
8	41310-93900	ROD, clamp BRKT lower	1	
9	41222-93E00	ARM, tilt lock	1	
10	45420-92002	PIN, tilt lock	1	
11	09100-06125	BOLT (6x140)	1	
12	09140-06020	NUT	1	
13	09162-06006	WASHER, lock	1	
14	09159-22003	NUT	1	
15	55320-95310	ZINK SEY, protection	1	
16	09116-06092	.BOLT	1	
17	41225-94400	RUBBER, tilt lock arm	1	
18	09111-10032	BOLT	1	
19	09160-10082	WASHER	1	
20	09448-29015	SPRING	1	
21	36894-95201	LEAD (clamp to swivel)	1	
22	09125-05050	SCREW (5x8)	2	
23	09161-05114	WASHER	2	
24	41141-89E00	ATTACHMENT, steering cable	1	OPT

COLOR : DED (Gray)

FIG.17

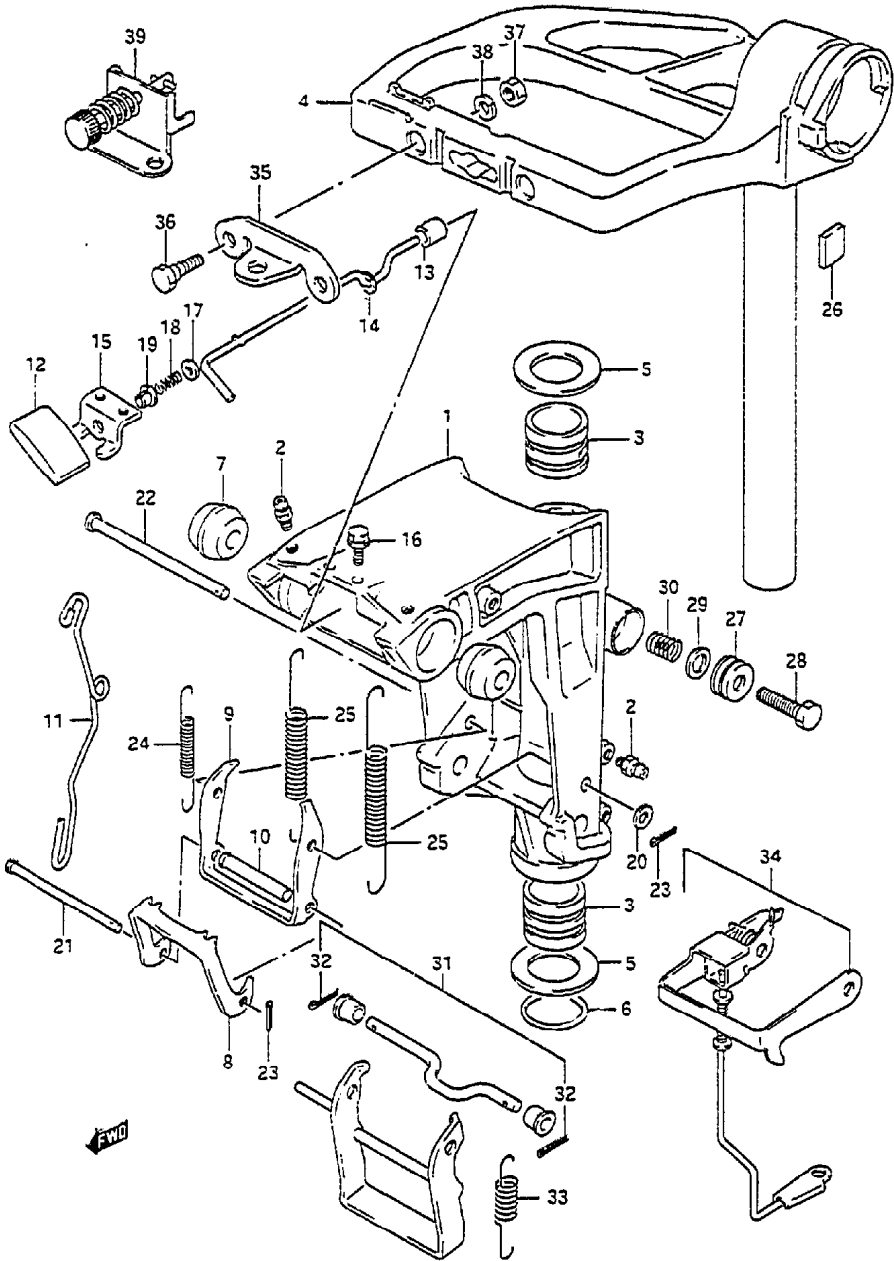

FIG.17 ( D- 4) SWIVEL BRACKET

REF.NO.	PART NO.	DESCRIPTION	Q'TY	REMARKS
1	43111-93923-OED	BRACKET, swivel	1	
2	22511-99010	NIPPLE	3	
3	43711-93901	BUSH, steering	2	
4	43750-93E00-OED	BRACKET, steering	1	
5	09160-27009	WASHER	2	
6	09280-27004	O RING	1	
7	09306-10012	BUSH, swivel bracket	2	
8	45231-93902	ARM, reverse lock	1	
9	45241-93901	LINK, reverse lock arm	1	
10	45246-93902	SPACER, reverse lock arm	1	
11	45252-93901	LINK, release lever	1	
12	45255-96302	KNOB, release lever	1	
13	45257-93900	BUSH, release lever	1	
14	45260-96300	LEVER, release	1	
15	45311-93900-OED	BRACKET, release lever	1	
16	09116-05010	BOLT	2	
17	09160-04012	WASHER	1	
18	09440-04021	SPRING	1	
19	09319-04001	BUSH	1	
20	09160-06082	WASHER	1	
21	09200-05014	PIN	1	
22	09200-06061	PIN	1	
23	09204-01001	COTTER PIN	2	
24	09443-05013	SPRING	1	
25	09443-11019	SPRING	2	
26	43411-93900	PLATE, steering adjuster	1	
27	43412-93900	COVER, steering adjuster	1	
28	09100-08232	BOLT	1	
29	09160-08082	WASHER	1	

COLOR : OED (Gray)

Refer to FIG.17A(D-6) for model:96,97

FIG.17 ( D- 5) SWIVEL BRACKET

Q'TY

REF.NO.	PART NO.	DESCRIPTION	Q'TY	REMARKS
30	09440-11022	SPRING	1	
31	45700-93911	SHALLOW WATER DRIVE ASSY	1	
32	09204-01001	.PIN, shallow drive	2	
33	09443-08031	.SPRING, shallow drive	1	
34	45200-93901	REVERSE LOCK SET	1	OPT
35	43755-93900	ATTACHMENT, steering bracket	1	OPT
36	09100-08224	BOLT	2	OPT
37	09140-08016	NUT	2	OPT
38	09162-08007	WASHER	2	OPT
39	67100-99700	ATTACHMENT, remote control	1	OPT

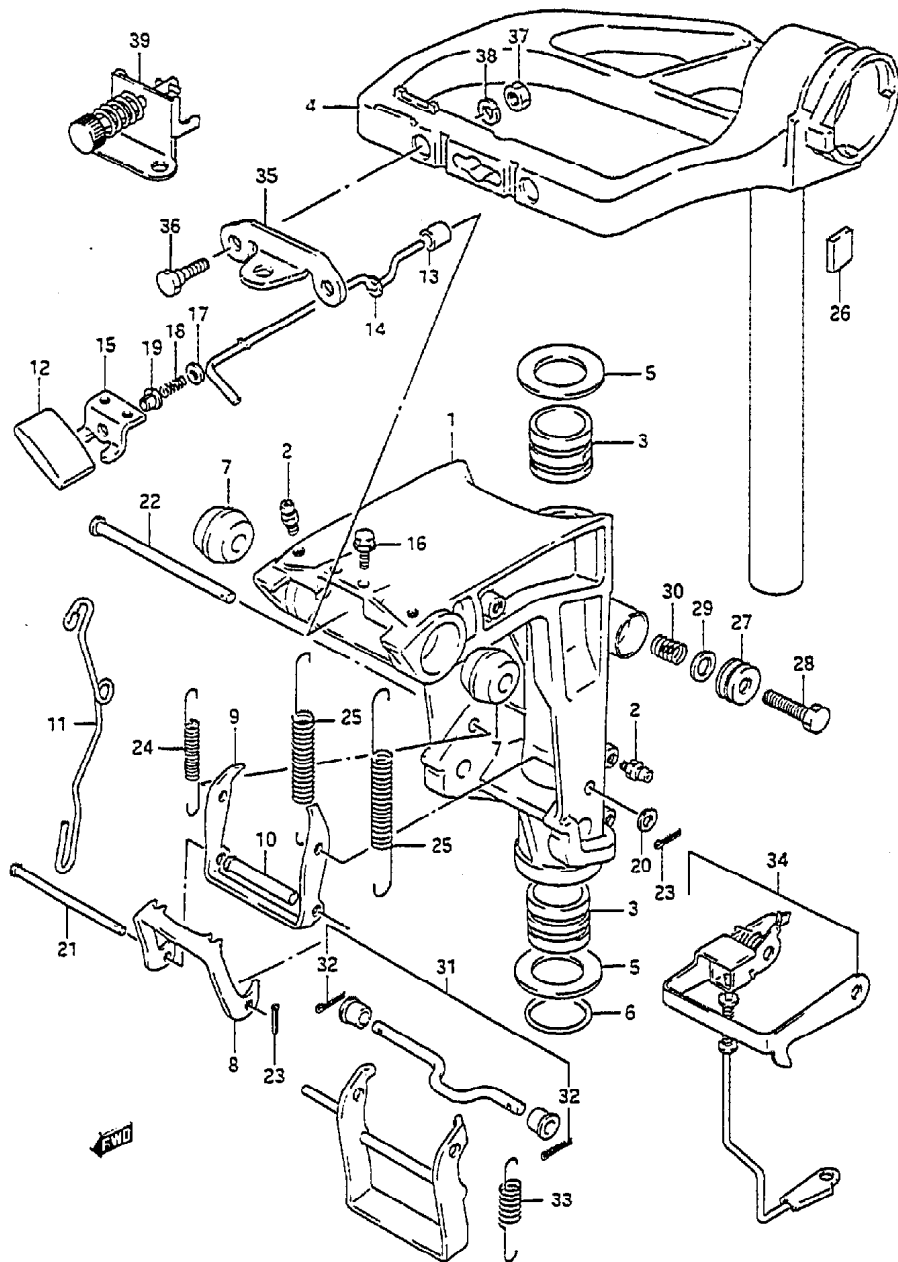

FIG.17A

FIG.17A( D- 6) SWIVEL BRACKET (MODEL:96,97)

Q'TY

REF NO.	PART NO.	DESCRIPTION	REMARKS
1	43111-93931-OED	BRACKET, swivel	
2	22511-99010	NIPPLE	
3	43711-93901	BUSH, steering	
4	43750-93E00-OED	BRACKET, steering	
5	09160-27009	WASHER (27.5x47x2.0)	
6	09280-27004	O RING	
7	43211-94401	BUSH, swivel BRKT	
8	09125-06063	SCREW	
9	09161-06120	GASKET	
10	45231-93902	ARM, reverse lock	
11	45241-93901	LINK, reverse lock arm	
12	41225-94501	PIN, release arm	
13	45250-89E01	LINK, release	
14	09306-22006	BUSH	
15	45255-93001	RUBBER, release lever	
16	45261-94400	LEVER, release	
17	09160-06082	WASHER	
18	09200-05014	PIN	
19	09200-06061	PIN	
20	09204-01001	PIN, cotter	
21	09448-29018	SPRING	
22	09443-11019	SPRING	
23	43411-93900	ADJUSTER, steering	
24	43412-93900	COVER, steering adjust	
25	09100-08232	BOLT (8x30)	
26	09160-08082	WASHER (8.5x16x1.2)	
27	09440-11022	SPRING	
28	45700-93911	DRIVE ASSY, shallow	OPT
29	09204-01001	.PIN	
30	09443-08031	.SPRING	
31	09407-30401	.CLAMP	
32	45200-93901	LOCK SET, reverse	OPT
33	67100-99700	ATTACHMENT, steering rope end	OPT

COLOR : OED (Gray)

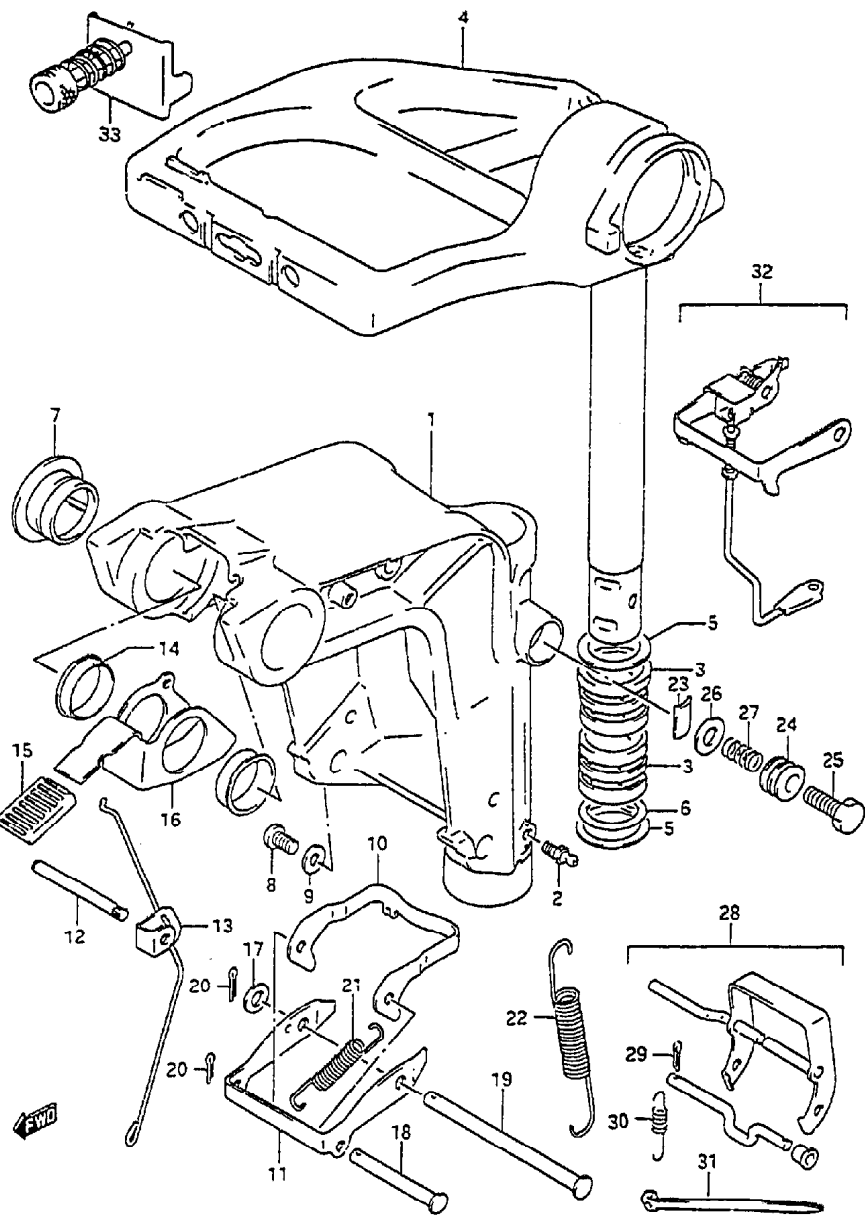



FIG. 18

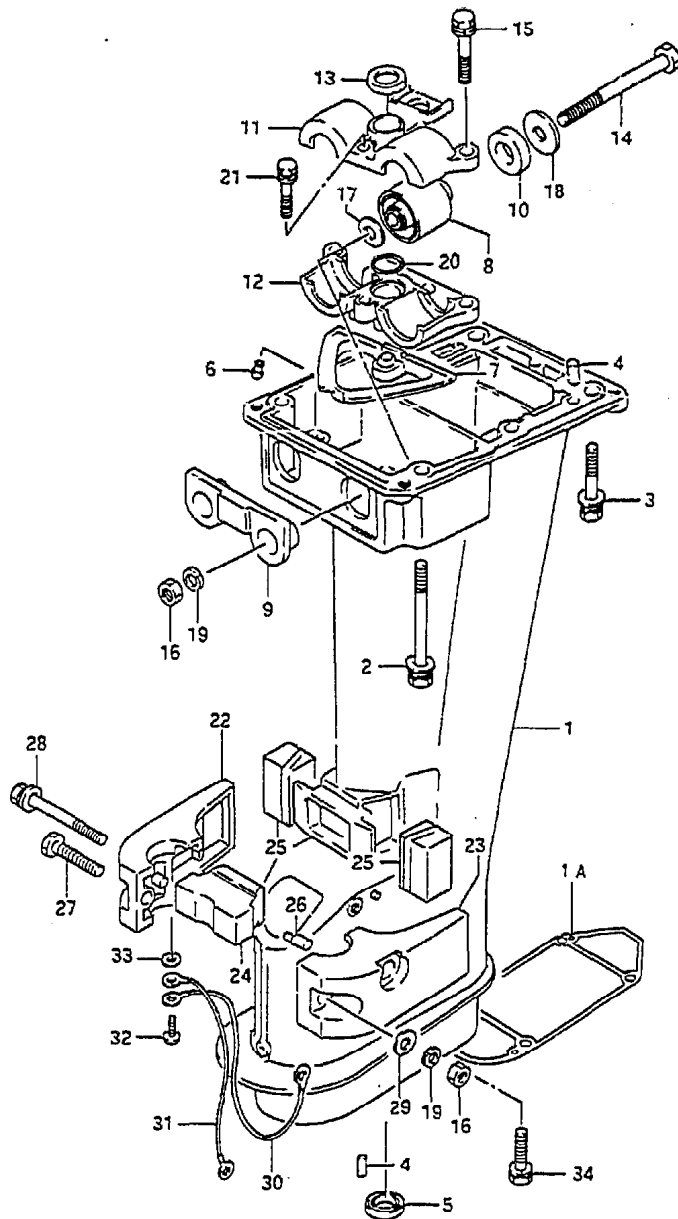

FIG. 18 ( D- 7) DRIVE SHAFT HOUSING

REF.NO.	PART NO.	DESCRIPTION	Q'TY	REMARKS
1-1	52111-89E11-OED	HOUSING, drive shaft (S)	1	
1-2	52111-89E01-OED	HOUSING, drive shaft (L)	1	
1A	55113-93E00	GASKEY, gear case	1	
2	09118-08098	BOLT (8x85)	2	
3	09118-08113	BOLT (8x45)	4	
4	09202-06023	PIN	4	
5	09282-13002	SEAL	1	
6-1	52117-94400	TUBE, water INSP	1	
6-2	52117-92000	TUBE, water INSP	1	581337~
7	52118-89E10	SEAL	1	
8-1	54130-93901	MOUNT, upper	2	
8-2	54130-93910	MOUNT, upper	2	model:93-97
9	54125-93901	MOUNT, upper thrust reverse	1	
10-1	54121-93900	CUSHION	2	
10-2	54121-92000	CUSHION	2	model:93-97
11	54135-89E00	COVER, upper mount upper	1	
12	54137-89E00	COVER, upper mount lower	1	
13	54145-89E01	SEAL	1	
14	09100-08209	BOLT (8x90)	2	
15	09117-08044	BOLT (8x40)	2	
16	09140-08016	NUT	3	
17	09160-08082	WASHER (8.5x16x1.2)	2	
18	09160-03084	STOPPER (8x30x2.5)	2	
19	09162-08007	WASHER	3	
20	09280-18005	O RING	1	
21	09117-06041	BOLT	1	
22	54211-93910-OED	COVER, lower mount STBD	1	
23	54221-93910-OED	COVER, lower mount PORT	1	
24	54151-93900	MOUNT, lower thrust	1	
25	54167-93900	MOUNT, lower side	1	
26	54213-93900	PIN	2	
27	09117-08056	BOLT (8x40)	1	

COLOR : OED (Gray)

FIG.18

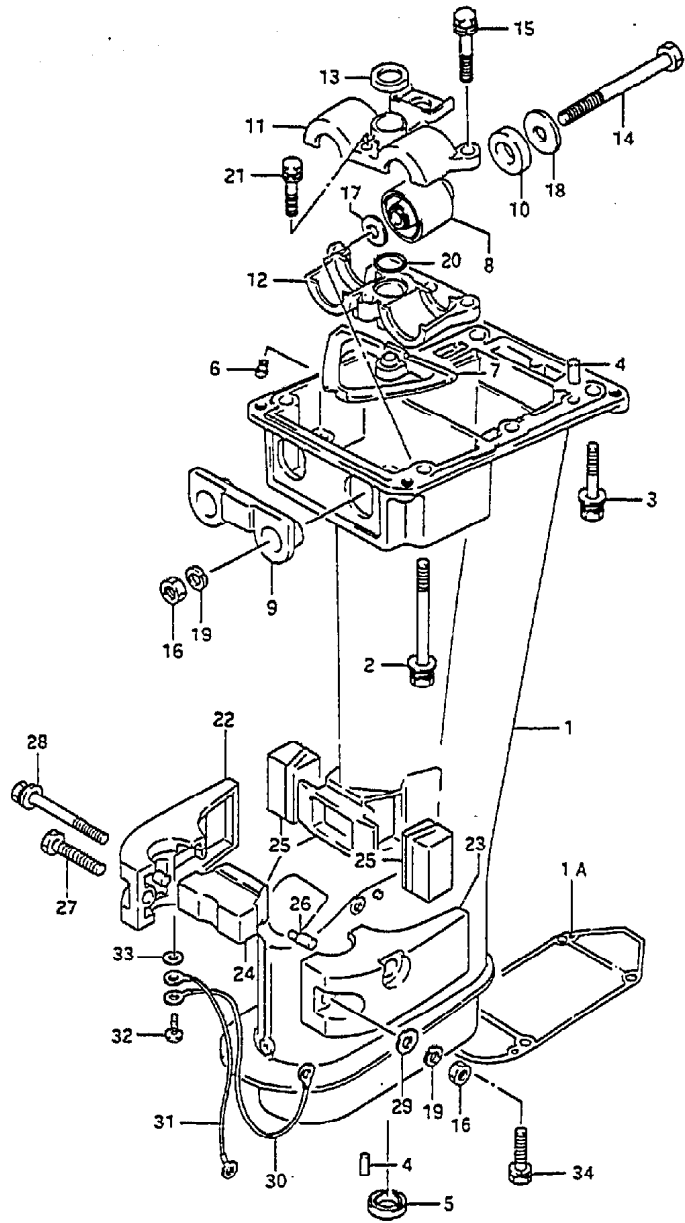
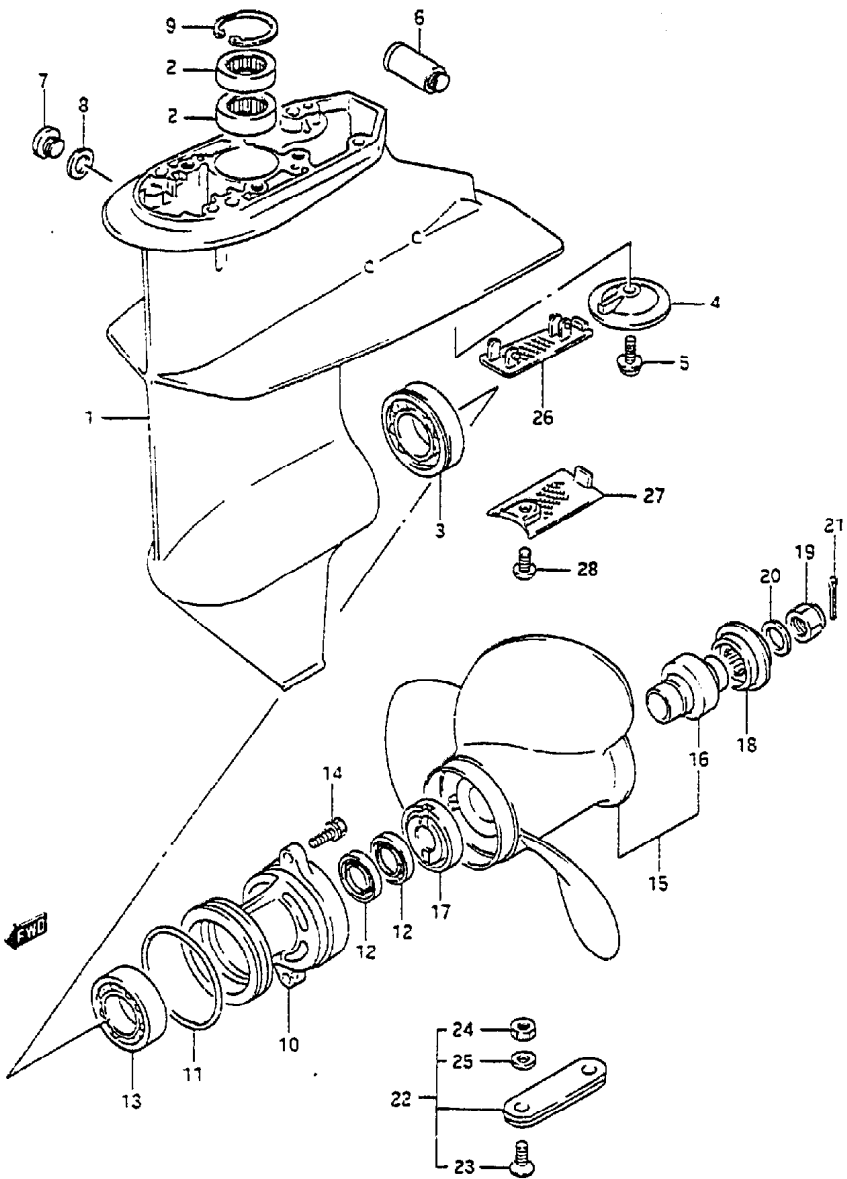

FIG.19 ( D- 8) DRIVE SHAFT HOUSING

REF.NO.	PART NO.	DESCRIPTION	Q'TY	REMARKS
28	09118-08137	BOLT (8x70)	2	
29	09160-08082	WASHER	2	
30-1	36894-94401	LEAD (swivel to mount)	1	L:195
30-2	36894-87000	LEAD (swivel to mount)	1	model:96,97
31	36894-95201	LEAD (mount to HSG)	1	L:165
32	09125-05050	SCREW (5x8)	3	
33	09161-05114	WASHER	3	
34	09117-08047	BOLT (8x30)	4	

FIG.19

FIG.19 ( D- 9) GEAR CASE



Q'TY

REMARKS

REF.NO.	PART NO.	DESCRIPTION	Q'TY	REMARKS
1-1	55100-93911-OED CASE, gear		1	model:89-91 →55100-93930-OED used with 17631-92001 09123-06063
1-2	55100-93930-OED CASE, gear		1	model:92-97
2	09263-15019	.BEARING (15x21x12)	2	
3	09262-25003	.BEARING	1	
4	55321-93900	.ZINK, protection	1	
5	09116-06094	.BOLT (6x15)	1	
6	55181-95200	ATTACHMENT, flush hose	1	OPT
7	09248-10008	PLUG, drain	3	
8	09168-10022	GASKEY (10x17x1.5)	3	
9	08331-41329	CIRCLIP, gear case	1	
10	56120-93900-OED HOUSING, propeller shaft		1	
11	09280-57002	O RING	1	
12	09289-17006	OIL SEAL	2	
13	08110-60050	BEARING	1	
14	09117-06031	BOLT (6x20)	2	
15-1	58100-93703-019 PROPELLER (3x9-1/4x7)		1	M701
15-2	58100-91D00-019 PROPELLER (3x9-1/4x8)		1	M801
15-3	58100-93723-019 PROPELLER (3x9-1/4x9)		1	M901
15-4	58100-93733-019 PROPELLER (3x9-1/4x10)		1	M1001
15-5	58100-93743-019 PROPELLER (3x9-1/4x11)		1	M1101
16	58120-93701	.BUSH, propeller	1	
17	57632-93901	STOPPER, propeller bush	1	
18	57633-93900	SPACER	1	
19-1	09159-12014	NUT	1	
19-2	09141-12005	NUT	1	model:94-97
20	09160-12066	WASHER	1	
21	09204-02004	COTTER PIN	1	

COLOR : OED (Gray)  
019 (Black)

FIG.19

FIG.19 ( D-10) GEAR CASE

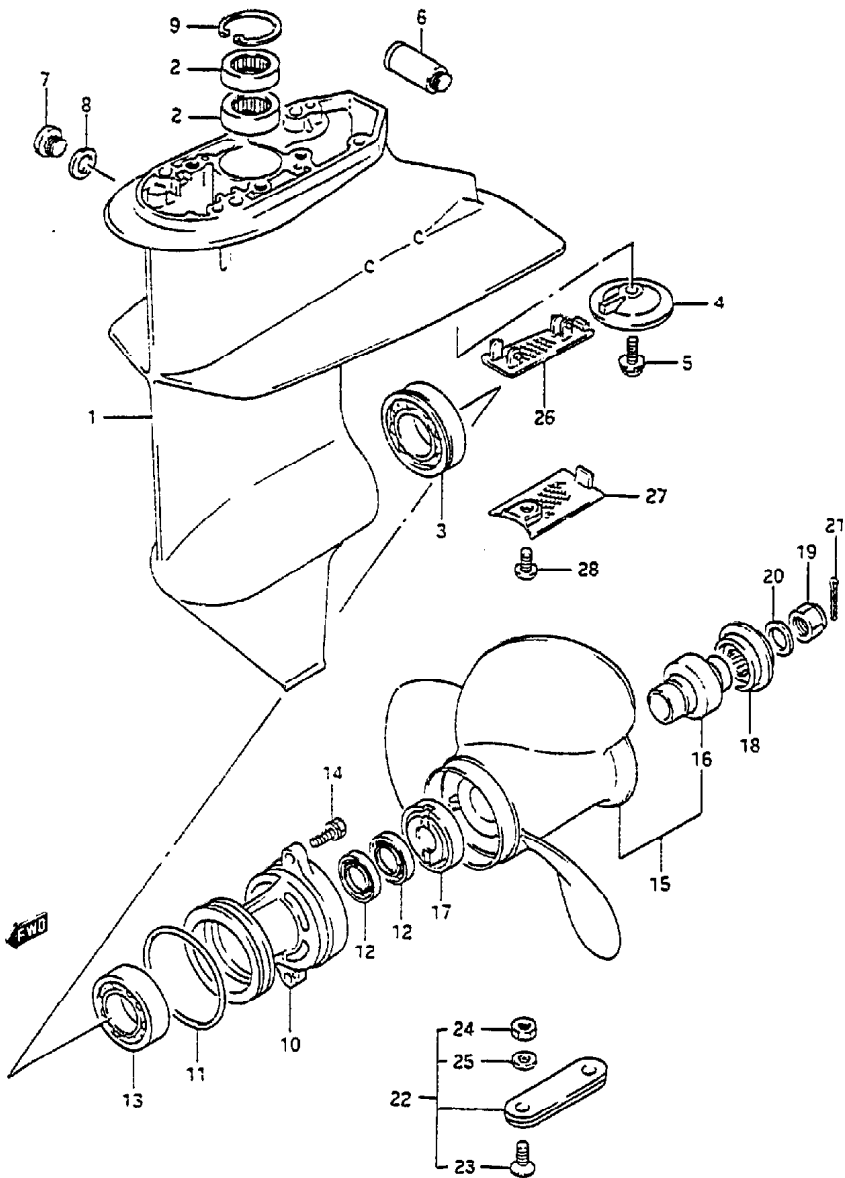

REF.NO.	PART NO.	DESCRIPTION	Q'TY	REMARKS
22	55300-95500	ZINC ASSY, protection	1	OPT
23	09126-06006	.SCREW (6x20)	2	
24	09140-06020	.NUT	2	
25	09162-06006	.LOCK WASHER	2	
26	17631-93901	FILTER, water	1	model:89-91
27	17631-92001	FILTER, water	1	model:92-97
28	09125-06063	SCREW (6x10)	1	model:92-97

FIG. 20

FIG. 20 ( D-11) TRANSMISSION

Q'TY

REMARKS

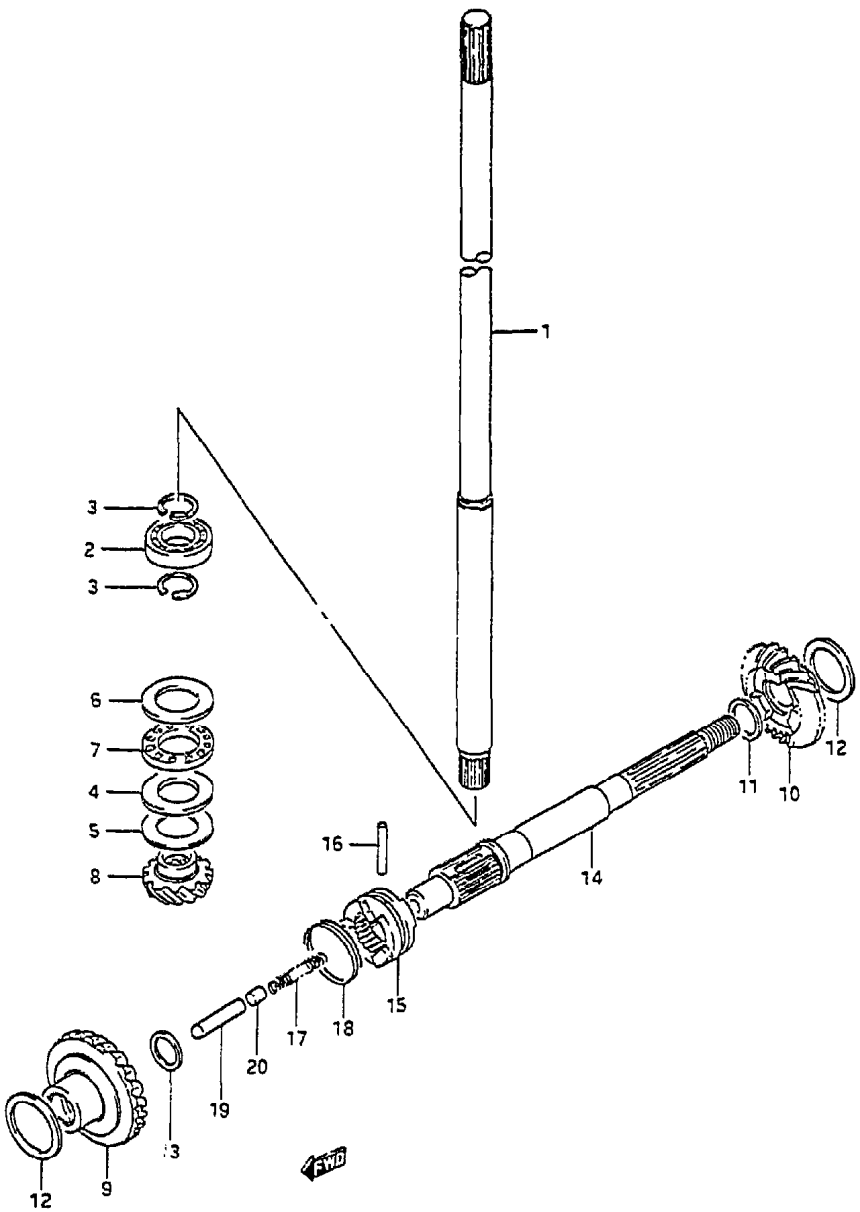

REF.NO.	PART NO.	DESCRIPTION	Q'TY	REMARKS
1-1	57100-89E12	SHAFT ASSY, drive (S)	1	
1-2	57100-89E02	SHAFT ASSY, drive (L)	1	
2	08110-60020	.BEARING	1	
3	09380-15001	.CIRCLIP	2	
4	09160-20027	WASHER (20x35x2.75)	1	
5-1	09160-20041	SHIM (T:1.0)	1	
5-2	09160-20042	SHIM (T:1.1)	1	
5-3	09160-20043	SHIM (T:1.2)	1	
5-4	09160-20044	SHIM (T:1.3)	1	
5-5	09181-20005	SHIM (T:0.7)	1	
5-6	09181-20244	SHIM (T:0.7)	1	model:97
5-7	09181-20006	SHIM (T:0.8)	1	
5-8	09181-20246	SHIM (T:0.8)	1	model:97
5-9	09181-20007	SHIM (T:0.9)	1	
5-10	09181-20248	SHIM (T:0.9)	1	model:97
6	09160-21009	WASHER (21x35x2.75)	1	
7	09263-20024	BEARING (20x35x4.5)	1	
8	57311-93901	PINION	1	
9	57510-93902	GEAR, foward	1	
10	57521-93902	GEAR, reverse	1	
11-1	09160-17024	WASHER (T:1.1)	1	
11-2	09160-17025	WASHER (T:1.3)	1	
11-3	09160-17026	WASHER (T:1.5)	1	
11-4	09160-17027	WASHER (T:1.7)	1	
11-5	09160-17028	WASHER (T:1.9)	1	
11-6	09160-17039	WASHER (T:1.2)	1	
11-7	09160-17040	WASHER (T:1.4)	1	
11-8	09160-17041	WASHER (T:1.6)	1	
11-9	09160-17042	WASHER (T:1.8)	1	

FIG. 20

FIG. 20 ( D-12) TRANSMISSION

Q'TY

REMARKS

REF. NO.	PART NO.	DESCRIPTION	Q'TY	REMARKS
12-1	09160-25040	SHIM (T:1.0)	2	
12-2	09160-25041	SHIM (T:1.1)	2	
12-3	09160-25042	SHIM (T:1.2)	2	
12-4	09160-25043	SHIM (T:1.3)	2	
12-5	09181-25053	SHIM (Y:0.7)	2	
12-6	09181-25160	SHIM (Y:0.7)	2	model:97
12-7	09181-25055	SHIM (Y:0.8)	2	
12-8	09181-25162	SHIM (Y:0.8)	2	model:97
12-9	09181-25057	SHIM (Y:0.9)	2	
12-10	09181-25164	SHIM (Y:0.9)	2	model:97
13-1	08211-15222	THRUST WASHER (Y:1.5)	1	
13-2	09181-15156	WASHER (Y:1.5)	1	model:97
14	57610-93901	SHAFT, propeller	1	
15	57621-93902	SHIFTER, clutch dog	1	
16	09202-04015	PIN	1	
17	09440-05027	SPRING	1	
18	09440-32008	SPRING	1	
19	57631-93901	ROD, push	1	
20	57632-98500	PIN	1	

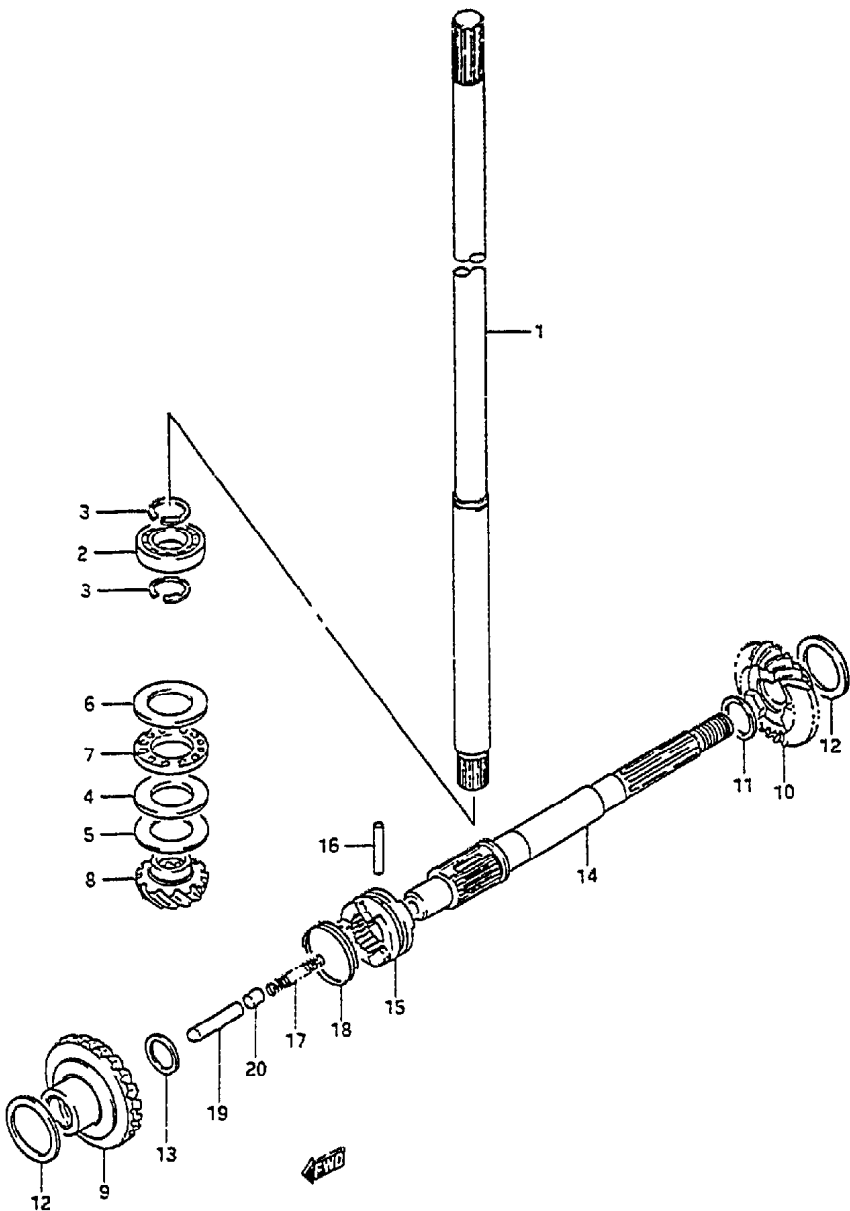

FIG. 21

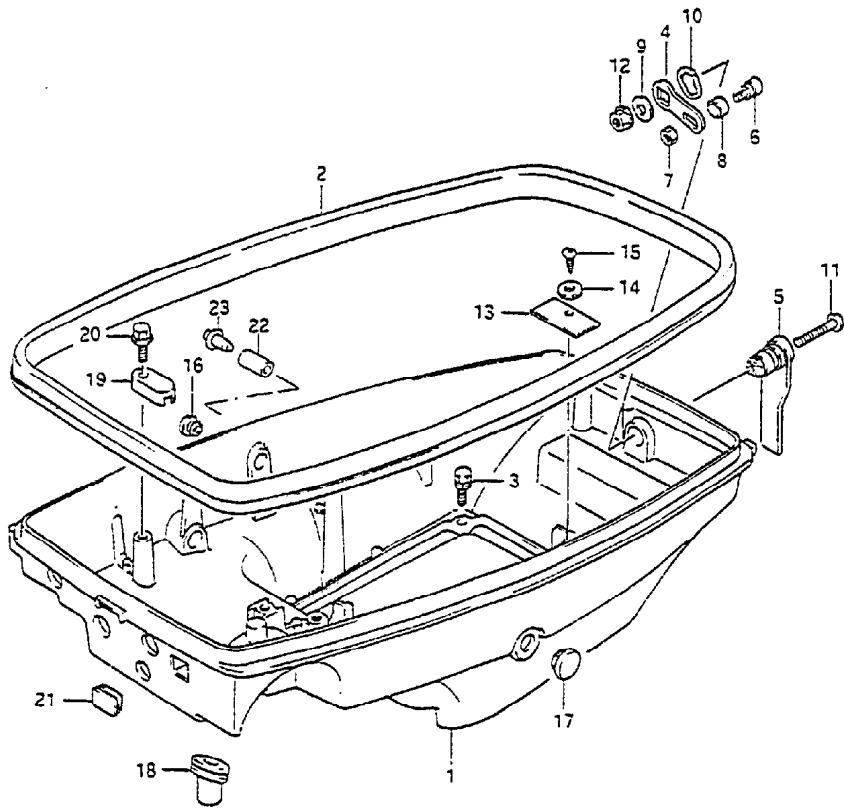

FIG.21 ( E- 2) LOWER COVER

REF.NO.	PART NO.	DESCRIPTION	Q'TY	REMARKS
1-1	61111-89E00-OED	COVER, engine lower	1	model:89,90 +61111-89E10-OED used with 39669-94400
1-2	61111-89E10-OED	COVER, engine lower	1	model:91-97
2	61112-93901	RUBBER, lower cover	1	
3-1	09117-06031	BOLT (6x20)	4	
3-2	09117-06046	BOLT (6x20)	4	model:96,97
4	61631-92000	HOOK, lower cover	1	
5	61633-92001	LEVER, hook	1	
6	61635-98602	PIN, lower cover hook	1	
7	08310-00067	NUT	1	
8	61636-98600	ROLLER, lower cover hook	1	
9	09160-06052	WASHER	1	
10	09164-14008	WASHER	1	
11	02112-06357	SCREW	1	
12	08316-10067	NUT	1	
13	61138-89E00	COVER, water	1	
14	09160-05024	WASHER	1	
15	03212-05103	SCREW	1	
16	09250-10012	CAP	1	-131382
17	09250-12006	CAP	1	
18	23131-93900	BODY, clutch rod	1	
19	36618-87000	STOPPER, wiring harness	2	
20	09103-06048	BOLT (6x20)	2	
21	39669-94400	PLUG, lower cover	1	manual starter
22	09354-53103-600	HOSE, remocon shaft hole	1	L:600*15 131383-
23	09409-06314-5PK	CAP, remocon shaft hole	1	131383-

COLOR : OED (Gray)  
SPK (Black)



FIG.22

FIG.22 ( E- 3) ENGINE COVER

Q'TY

REMARKS

REF.NO.	PART NO.	DESCRIPTION	Q'TY	REMARKS
1	61400-89011-0ED	COVER SET, engine	1	
2	61412-89E00	.HOOK, engine cover	1	
3	61611-89E00	.FASTENER	1	
4	09220-05005	.RIVET	4	
5	61433-89E00	.COVER, air intake inner	1	
6	61622-93901	.SEAL, recoil starter	1	
7	03212-14129	.SCREW	4	
8	61422-93960-70G	.MARK, emblem front	1	-model:92
9	61435-89E00-70G	.MARK, emblem rear	1	
10	61441-96310-764	.EMBLEM, SUZUKI	2	
11	61442-92000-764	.MARK, oil injection	2	
12	61443-89E00-70G	.DECAL, STBD	1	
13	61453-89E00-70G	.DECAL, PORT	1	
14	21131-96003	MARK, clutch shift	1	
15	09800-01001	TOOL ASSY	1	
16	61582-98100	MARK, warning	1	

COLOR : 0ED (Gray)  
 70G (764/019)  
 764 (Gold)  
 019 (Black)

Refer to FIG.23(E-4) for MODEL:94-97

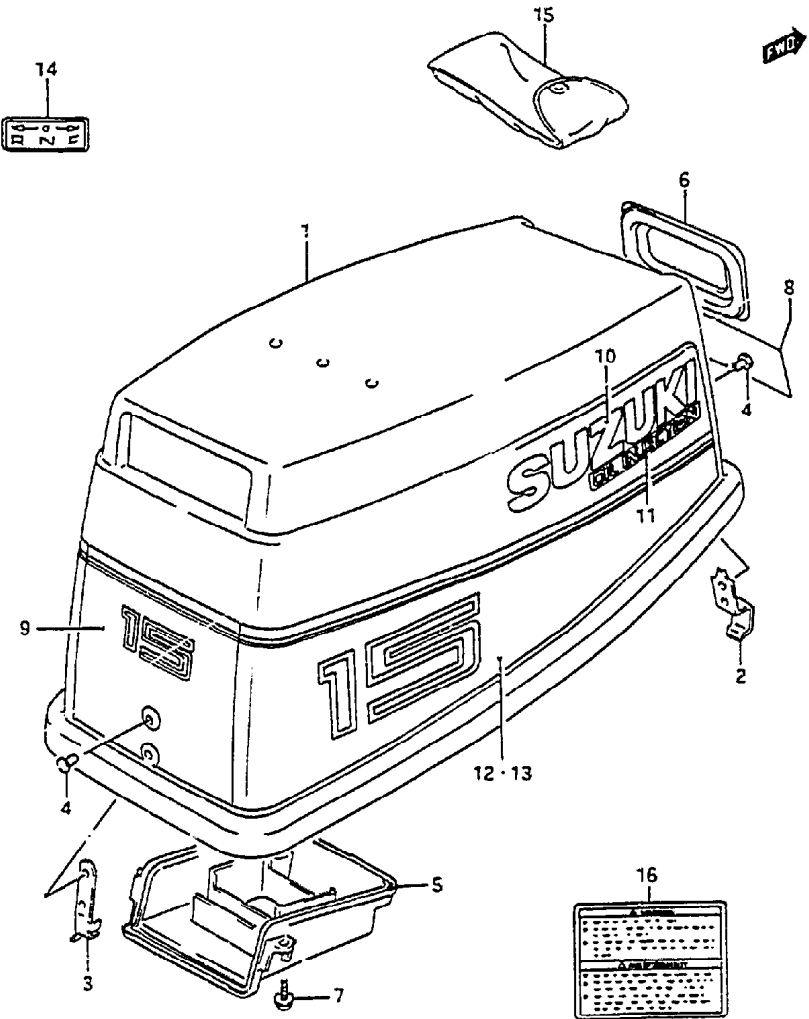



FIG. 23

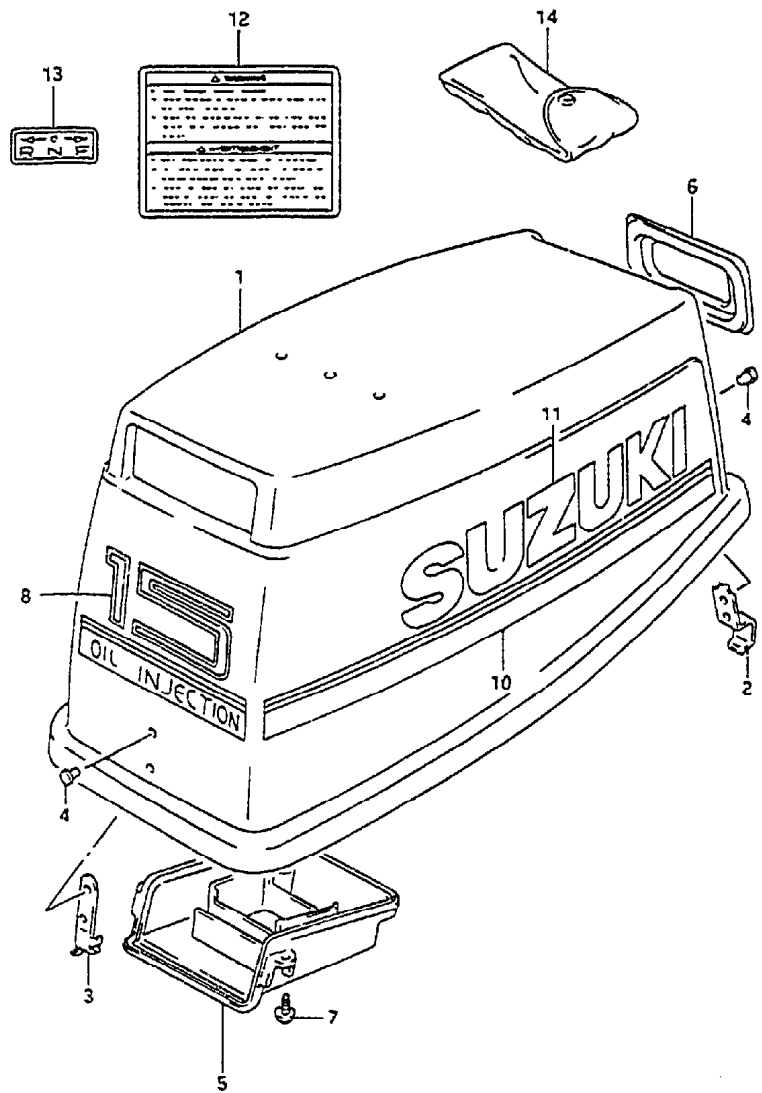
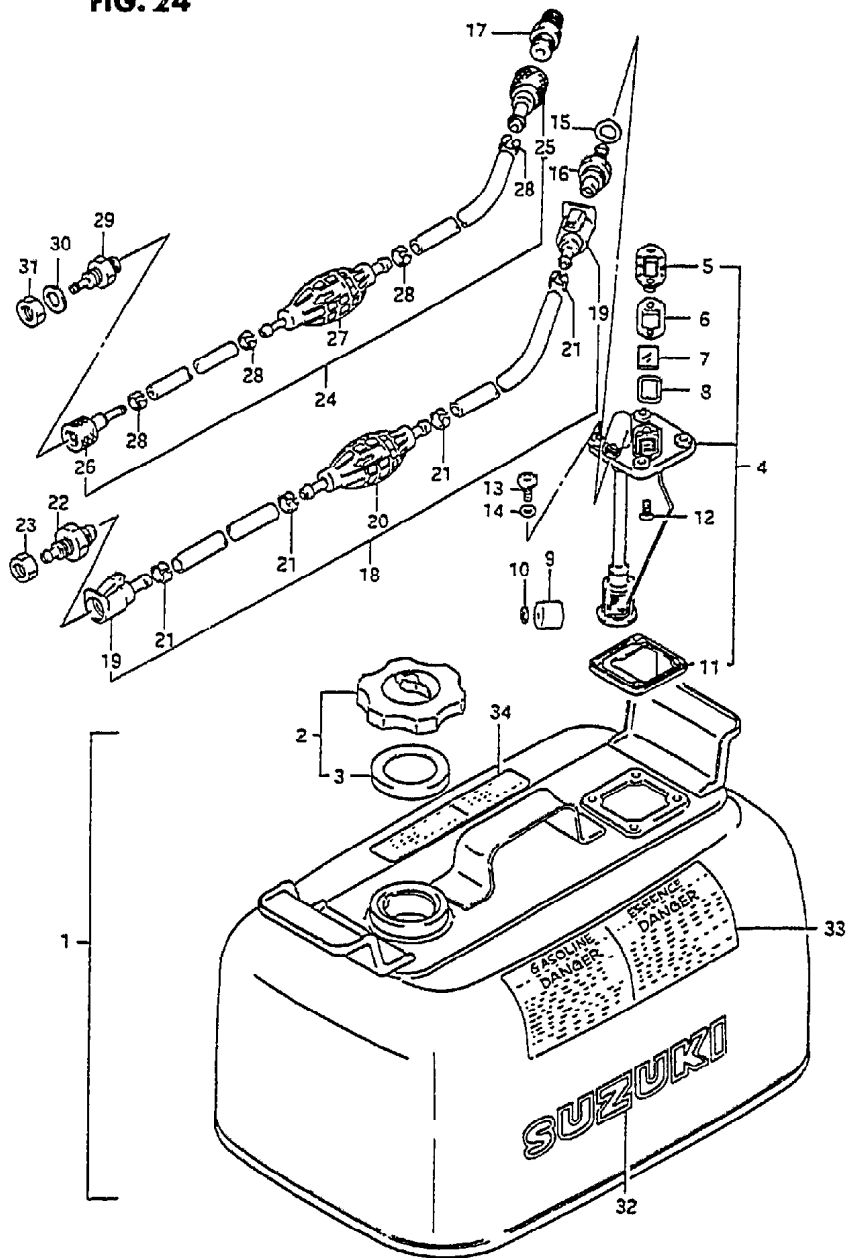

FIG. 23 ( E- 4) ENGINE COVER (MODEL:94-97)

REF. NO.	PART NO.	DESCRIPTION	Q'TY	REMARKS
1	61400-89821-OED	COVER SET, engine	1	
2	61412-89E00	.HOOK, engine cover	1	
3	61611-89E00	.FASTENER	1	
4	09220-05005	.RIVET	4	
5	61433-89E00	.COVER, air intake inner	1	
6	61622-93901	.SEAL, recoil starter	1	
7	03242-04123	.SCREW	4	
8	61435-89E11	.MARK, emblem rear	1	
10	61440-91D00	.STRIPE SET	1	
11	68181-33C20-IRR	.EMBLEM, SUZUKI	2	
12	61581-98610	MARK, safety warning	1	
13	21131-96003	MARK, clutch shift	1	
14	09800-01001	TOOL SET	1	

COLOR : OED (Gray)  
IRR (Gold)

FIG. 24



32

FIG.24 ( E- 5) FUEL TANK (STEEL)

REF.NO.	PART NO.	DESCRIPTION	Q'TY	REMARKS
1	65800-92B23	TANK SET, fuel (24L)	1	
2	65510-92D00	.CAP ASSY, separate tank	1	
3	65561-92D00	..GASKET, tank cap	1	
4	65850-92D01	.GAUGE ASSY, fuel	1	
5	65855-92D10	..COVER, gauge	1	
6	65854-92D20	..GASKET, gauge cover	1	
7	65853-92D00	..LENS	1	
8	65854-92D30	..GASKET, gauge lens	1	
9	65864-92D00	..FLOAT	1	
10	65866-92D00	..PUSH, nut	1	
11	65871-92D00	..GASKET, fuel	1	
12	03221-04083	..SCREW	2	
13	02112-16167	.SCREW	4	
14	09168-06026	.GASKEY	4	
15	09168-12015	.GASKEY	1	
16	65720-94411	.CONNECTOR, fuel	1	
17	65740-95500	.CONNECTOR, fuel	1	231795-
18	65700-87D16	HOSE, fuel	1	-model:92
19	65750-94404	.CONNECTOR, fuel	1	
20	65770-95504	.PUMP, squeeze	1	
21	65781-98500	.CLIP	4	
22	65720-94401	CONNECTOR, fuel	1	
23	08310-00107	NUT	1	
24	65700-87D17	HOSE, fuel	1	231795-
25	65750-95500	.SOCKET, IN	1	231795-
26	65750-98505	.SOCKET, OUT	1	231795-
27	65770-95540	.PUMP, squeeze	1	231795-
28	65781-98500	.CLIP	4	231795-
29	65720-98520	CONNECTOR, fuel	1	231795-
30	09160-10082	WASHER	1	231795-
31	09140-10032	NUT	1	231795-
32	61441-98500	MARK, ornament	1	
33	65316-93331	MARK, fuel caution	1	
34	65317-95260	MARK, fuel capacity	1	

Refer to FIG.25(E-6) for FUEL TANK (PLASTIC)

FIG. 25

FIG. 25 ( E- 6) FUEL TANK (PLASTIC)

Q'TY

REF.NO.	PART NO.	DESCRIPTION	Q'TY	REMARKS
1	65000-95000	TANK ASSY, fuel (25L)	1	
2	65520-95000	.CAP, fuel tank	1	
3	65561-95000	.GASKET, tank cap	1	
4	65831-95000	.FILTER, outlet	1	
5	65890-95000	.OUTLET ASSY	2	
6	65892-95000	.O RING, fuel outlet	1	
7	65740-95000	.PLUG, fuel connector	1	
8	65720-98520	PLUG, fuel connector	1	
9	09160-10082	WASHER	1	
10	09140-10032	NUT	1	
11	65700-87017	HOSE, fuel	1	
12	65750-95500	.SOCKET, in	1	
13	65750-98505	.SOCKET, out	1	
14	65770-95540	.PUMP, squeeze	1	
15	65781-98500	.CLIP	4	

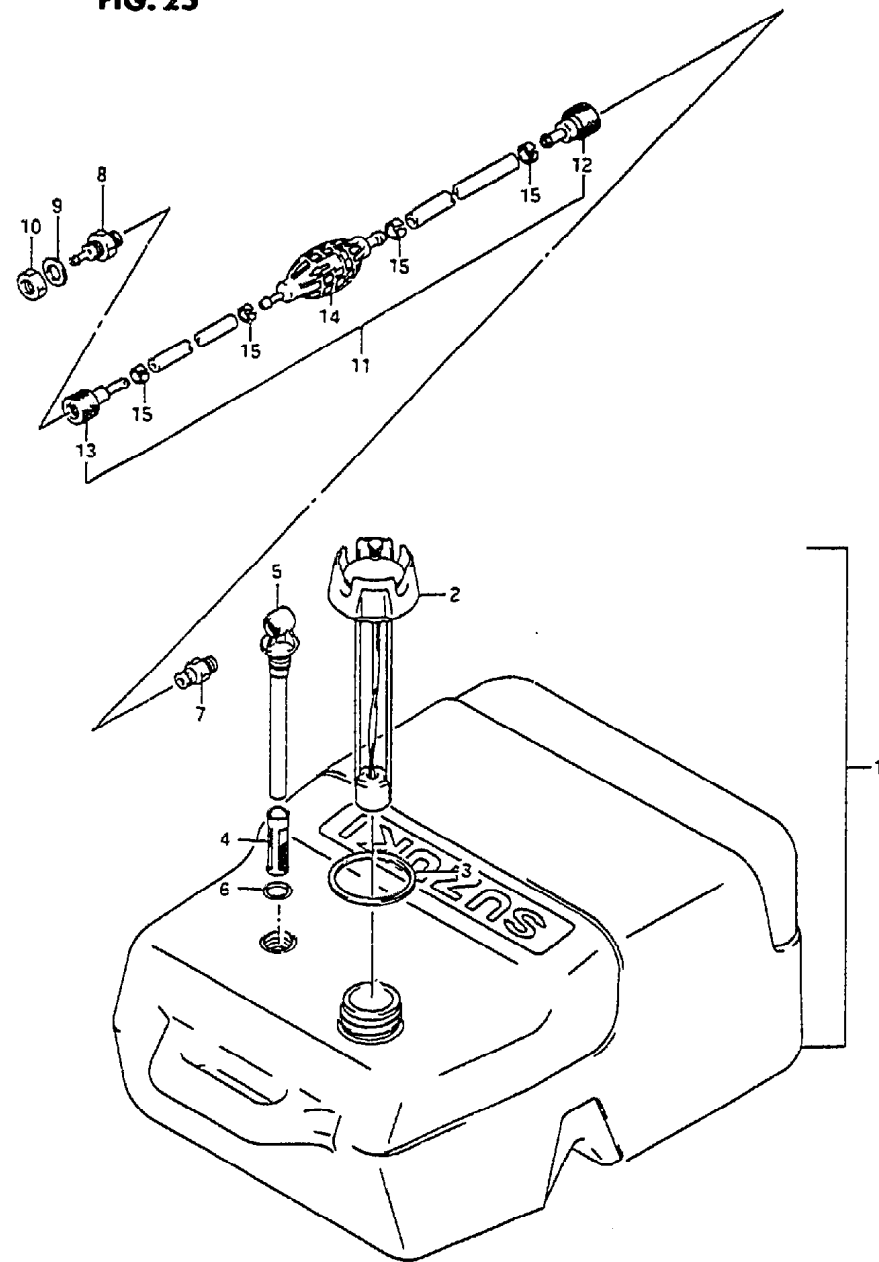
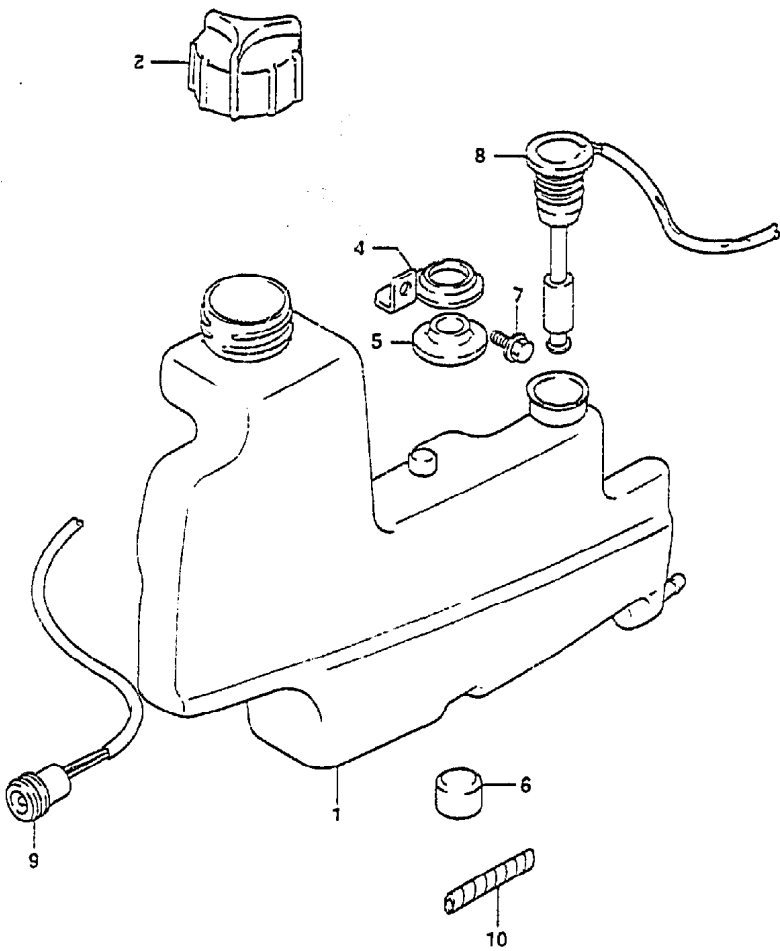

FIG. 26

FIG.26 ( E- 7) OIL TANK



REF.NO.	PART NO.	DESCRIPTION	Q'TY	REMARKS
1	69111-89E00	TANK, oil	1	
2	69200-89E20	CAP, oil tank filler	1	
4	69311-89E00	SUPPORT, oil tank	1	
5	09320-12044	CUSHION, oil tank support	1	
6	09329-12004	CUSHION, oil tank	3	
7	01550-06127	BOLT	1	
8	34860-89E01	SWITCH, oil level	1	
9	36360-89E00	INDICATOR, oil level	1	
10	38423-95510	TUBE	1	L:150+50

FIG. 27

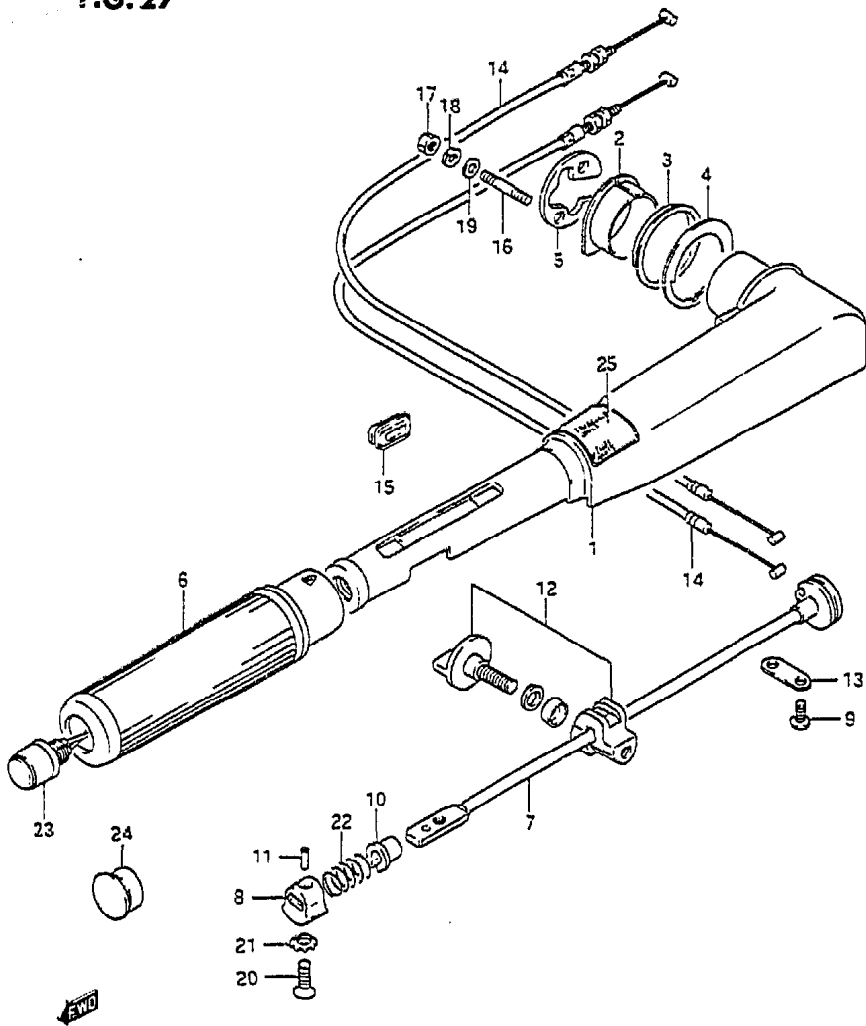

FIG. 27 ( E- 8) HANDLE

Q'TY

REF.NO.	PART NO.	DESCRIPTION	Q'TY	REMARKS
1	63111-92010-OED	HANDLE, tiller	1	
2	63115-92001	BUSH, tiller handle	1	
3	63116-92001	BUSH, tiller handle side	1	
4	63117-92000	WASHER, tiller handle	1	
5	63125-92001	PLATE, tiller handle	1	
6	63210-93E00	GRIP, handle	1	
7	63220-92003	ROD, handle	1	
8	63223-89E00	STOPPER, handle rod	1	
9	09125-05046	SCREW	2	
10	63225-93200	BUSH, handle rod	1	
11	63227-93200	PIN, handle rod	1	
12	63240-96300	ADJUSTER SET, handle grip	1	
13	63241-92000	SUPPORT, handle rod	1	
14	63610-89E01	CABLE ASSY, throttle	2	
15	63625-96300	GROMMET, throttle cable	1	
16-1	09108-06062	STUD BOLT	2	
16-2	09108-06060	STUD BOLT	2	model:96,97
17-1	09140-06020	NUT	2	
17-2	09159-06079	NUT	2	model:96,97
18	09162-06006	WASHER, lock	2	
19	09160-06055	WASHER	2	
20-1	09126-06006	SCREW	1	
20-2	09126-06015	SCREW	1	model:94-97
21	09163-06001	WASHER	1	
22	09440-12027	SPRING	1	
23	37800-89E12	SWITCH, stop	1	~model:92
24	63213-94400	CAP, stop SW	1	
25	63215-93400	MARK, handle grip	1	

COLOR : OED (Gray)

FIG. 28

FIG.28 ( F- 2) OPT : ELECTRICAL (1)

Q'TY

REMARKS

REF.NO.	PART NO.	DESCRIPTION	Q'TY	REMARKS
1-1	31101-89E00	MOTOR SET, starter	1	model:89,90
1-2	31101-89E10	MOTOR SET, starter	1	model:91,92
1-3	31101-89E11	MOTOR SET, starter	1	232153-
2	32102-89E00	FLYWHEEL, magneto	1	
3	32801-89E00	RECTIFIER SET	1	
4	36740-89E00	.CASE, fuse	1	
5	03212-05253	.SCREW	1	
6	32800-95D01	.RECTIFIER	1	
7-1	33800-89E02	CABLE & SWITCH SET	1	
7-2	33800-89E03	CABLE & SWITCH SET	1	232153-

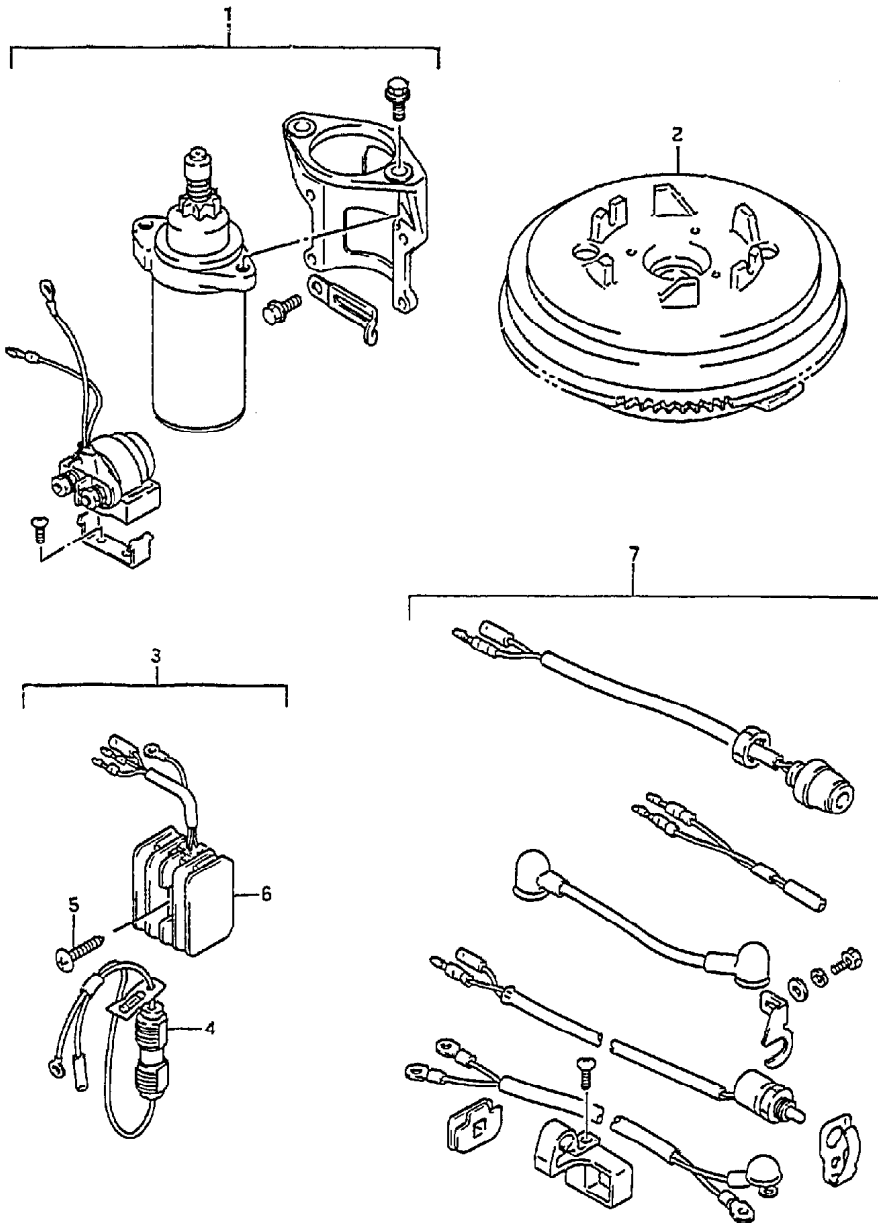

FIG. 29

FIG. 29 ( F-3) OPT : ELECTRICAL (2)

Q'TY

REMARKS

REF NO.	PART NO	DESCRIPTION	Q'TY	REMARKS
1	32501-89E00	REGULATOR SET	1	
2	32500-95722	.UNIT, voltage regulator	1	
3	32590-89E00	.BRACKET, regulator	1	
4	02162-06127	.BOLT	2	
5	08310-00067	.NUT	2	
6	39602-93900	PLUG ASSY, lighting	1	
7	32801-89E51	RECTIFIER SET	1	
7A	32800-95D01	.RECTIFIER	1	
8	36740-92052	.CASE, fuse	1	
9	37801-98300	.LEAD, receptacle ground	1	
10	03212-05253	.SCREW	1	
11	36612-92D00	GROMMET, remocor; harness	1	
12-1	36630-89E01	HARNESS, wiring remocor	1	
12-2	36630-89E02	HARNESS, wiring remocor	1	model:97
13	36631-94300	.CAP	1	
14	36632-95501	CLAMP	1	
15	37823-94400	CAP, emergency SW	1	
16	38600-89E00	SOLENOID, choke	1	
17	01500-05127	.BOLT	2	
18	08310-00057	.NUT	2	
19	08321-01057	.LOCK WASHER	2	
20	08322-01057	.WASHER	2	
21	38500-92D10	BUZZER	1	
22	37824-92D00	.GROMMET	1	
23	03142-05253	.SCREW	1	
24	36990-87D00	TERMINAL & SLEEVE SET	1	

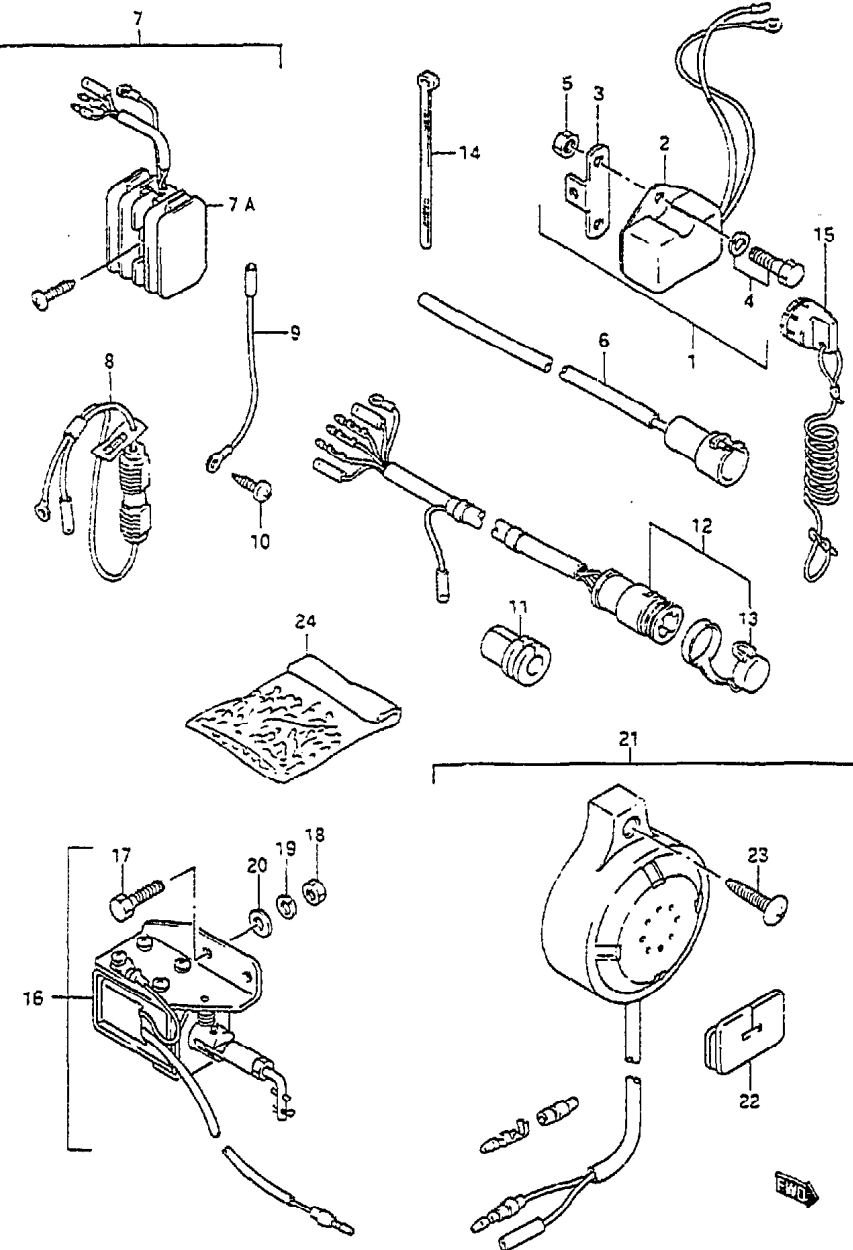

FIG.30

FIG.30 ( F- 4) OPT : REMOTE CONTROL PARTS

Q'TY

REF.NO.	PART NO.	DESCRIPTION	REMARKS
1	67130-89810	REMOTE CONTROL PARTS ASSY	1
2	67340-89E00	.HOLDER, remocon cable	1
3	09100-06089	.BOLT	1
4	09100-06083	.BOLT	1
5	09162-06006	.WASHER	2
6	09140-06020	.NUT	2
7	67440-93900	.GUIDE, clutch cable	1
8	67410-89E01	.LEVER, remocon throttle	1
9	09119-06047	.PIVOT, ball	1
10	09306-08014	.BUSH, throttle shaft No.2	2
11	09306-08003	.BUSH, throttle shaft No.1	1
12	09164-10009	.WASHER	1
13	67413-89E00	.ROD, throttle control	1
14	19131-95502	.CONNECTOR, remocon rod	2
15	09140-05005	.NUT	1
16	67417-89E00	.ARM, remocon throttle	1
17	09159-08059	.NUT	1
18	67466-95200	.CONNECTOR, remocon cable	1
19	09209-05017	.CONNECTOR, throttle control	1

COLOR : OED (Gray)

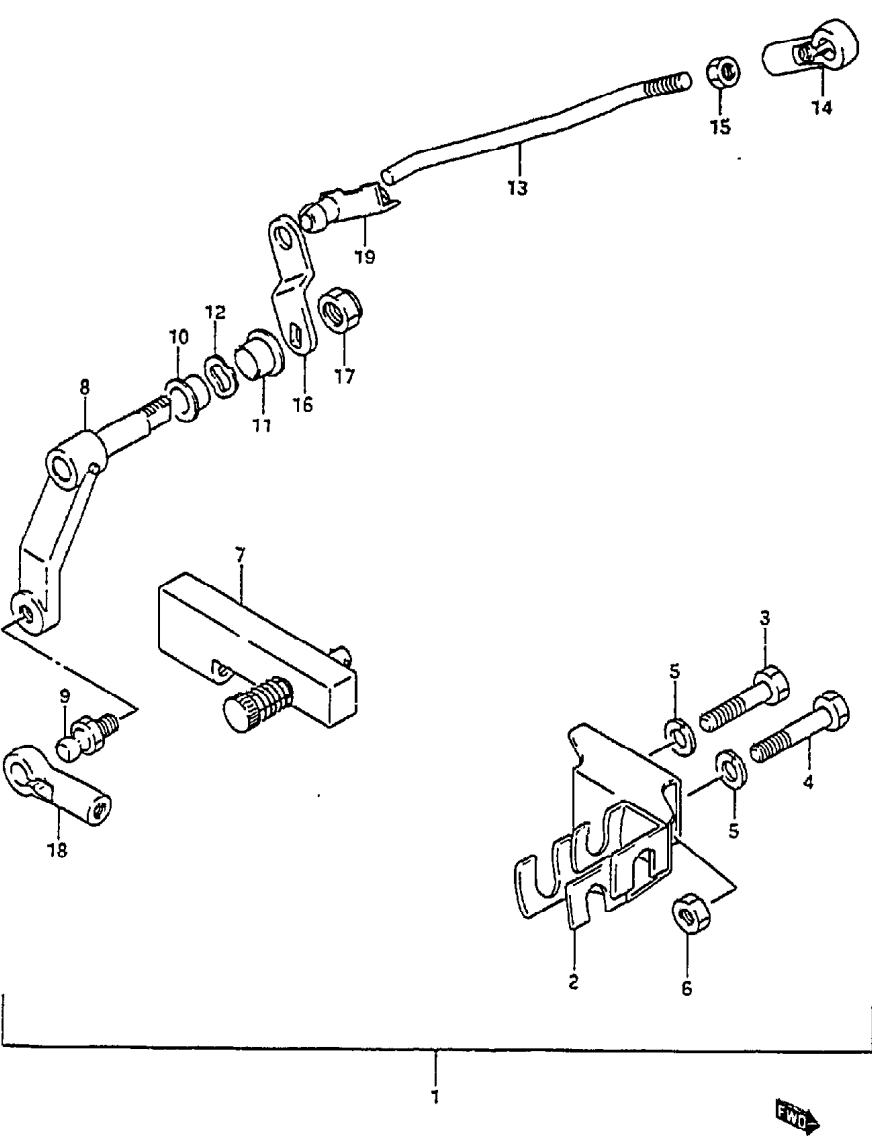



FIG.31

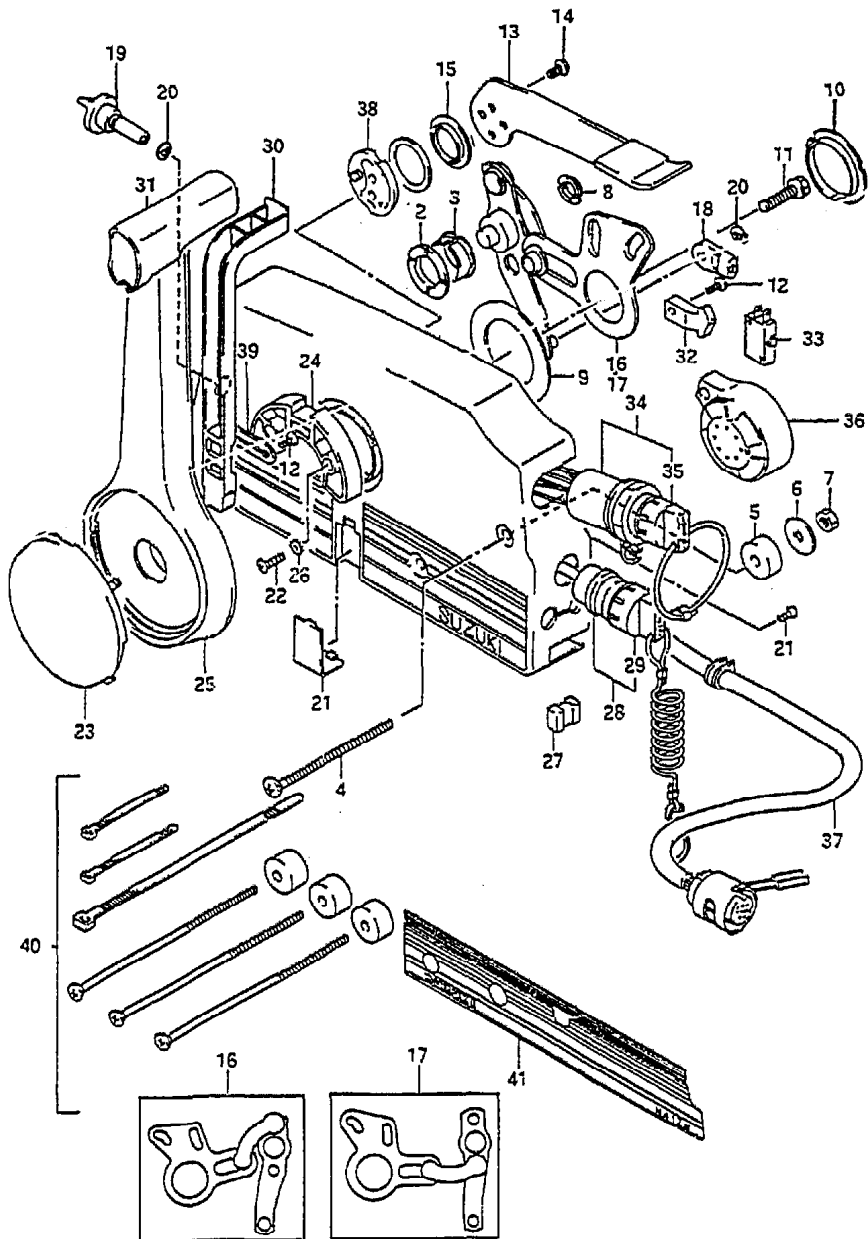

FIG.31 ( F- 5) OPT : REMOTE CONTROL (MODEL:89-92)

REF.NO.	PART NO.	DESCRIPTION	Q'TY	REMARKS
1-1	67200-94442-OED	REMOTE CONTROL BOX ASSY	1	W/pull, for electric +67200-87030-OED
1-2	67200-93961-OED	REMOTE CONTROL BOX ASSY	1	W/pull, for manual +67200-93990-OED
1-3	67200-89E02-OED	REMOTE CONTROL BOX ASSY	1	W/push, +67200-89E12-OED
2	67232-95600	.BUSH	1	
3	67232-95620	.BUSH	1	
4	67296-95600	.SCREW	3	
5	67294-95600	.SPACER	3	
6	09160-06104	.WASHER	3	
7	09140-06020	.NUT	3	
8	67232-95610	.BUSH	2	
9	67253-95600	.WASHER	1	
10	67252-95600	.BUSH	2	
11	09100-08232	.BOLT (3x30)	1	
12	67296-94300	.SCREW	3	
13	67241-95680	.LEVER, free throttle	1	
14	09126-05003	.SCREW	2	
15	67243-95600	.BUSH	1	
16	67220-95600	.PLATE ASSY	1	W/pull
17	67220-95630	.PLATE ASSY	1	W/push
18	67275-95600	.END, cable	2	
19	67223-95600	.KNOB, brake ADJ	1	
20	67292-94300	.E RING	3	
21	67267-95620	.COVER, wire	1	
22	67296-95610	.SCREW	7	
23	67257-95610	.CAP, lever	1	
24	67256-95600	.HOLDER, neutral lock	1	
25	67251-95680	.LEVER, handle	1	
26	67297-95600	.WASHER	2	
27	67273-95600	.SPACER	1	
28	37820-94404	.SWITCH ASSY, emergency	1	+37820-92E00
29	37823-94400	.CAP & ROPE	1	

COLOR : OED (Gray)

Refer to FIG.32 (F-7) for REMOTE CONTROL (MODEL:93-97)

FIG.31

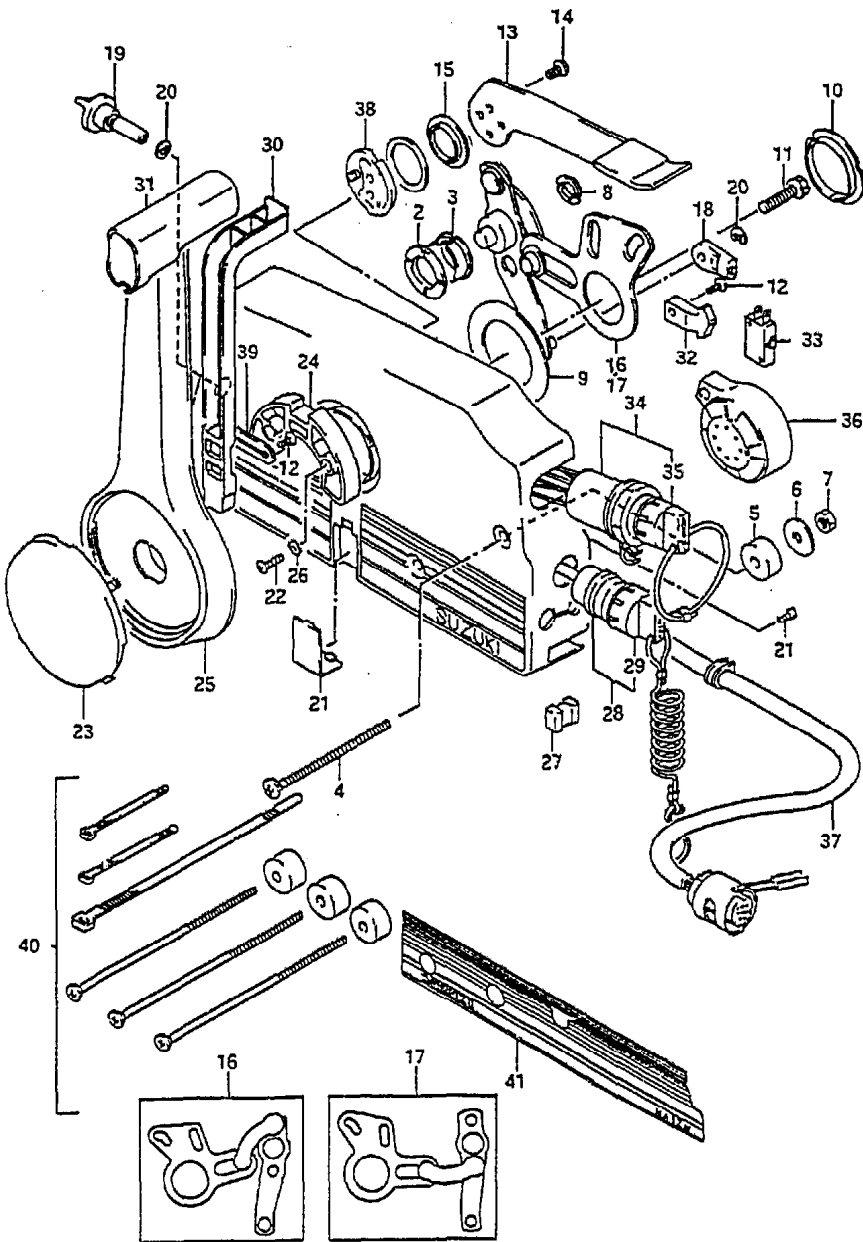

40

FIG.31 ( F- 6) OPT : REMOTE CONTROL (MODEL:89-92)

REF.NO.	PART NO.	DESCRIPTION	Q'TY	REMARKS
	1			
30	67255-95600	.ARM, neutral lock	1	
31	67261-95610	.GRIP	1	
32	67214-95600	.ACTUATOR	1	
33	37721-94600	.SWITCH, neutral	1	
34	37110-94611	.SWITCH ASSY, IGN	1	+37110-92E00
35-1	37141-94400	..KEY (101)	1	
35-2	37141-94410	..KEY (102)	1	
35-3	37141-94420	..KEY (103)	1	
35-4	37141-94430	..KEY (104)	1	
35-5	37141-94440	..KEY (105)	1	
35-6	37141-94450	..KEY (106)	1	
36	38500-92X50	.BUZZER	1	
37-1	36620-92E00	.HARNESS ASSY, wiring	1	for 67200-94442-OED
37-2	36620-95D00	.HARNESS ASSY, wiring	1	for 67200-89E02-OED 67200-93961-OED
38	67245-95600	.DRUM ASSY, throttle	1	
39	67258-87D00	.BRACKET, neutral arm	1	
40	67140-95600	ATTACHMENT KIT, twin remocon	1	
41	67282-95610	DECAL, remocon box PORT	1	OPT,Black

FIG.32

41

FIG.32 ( F- 7) OPT:REMOTE CONTROL (model:93-97)

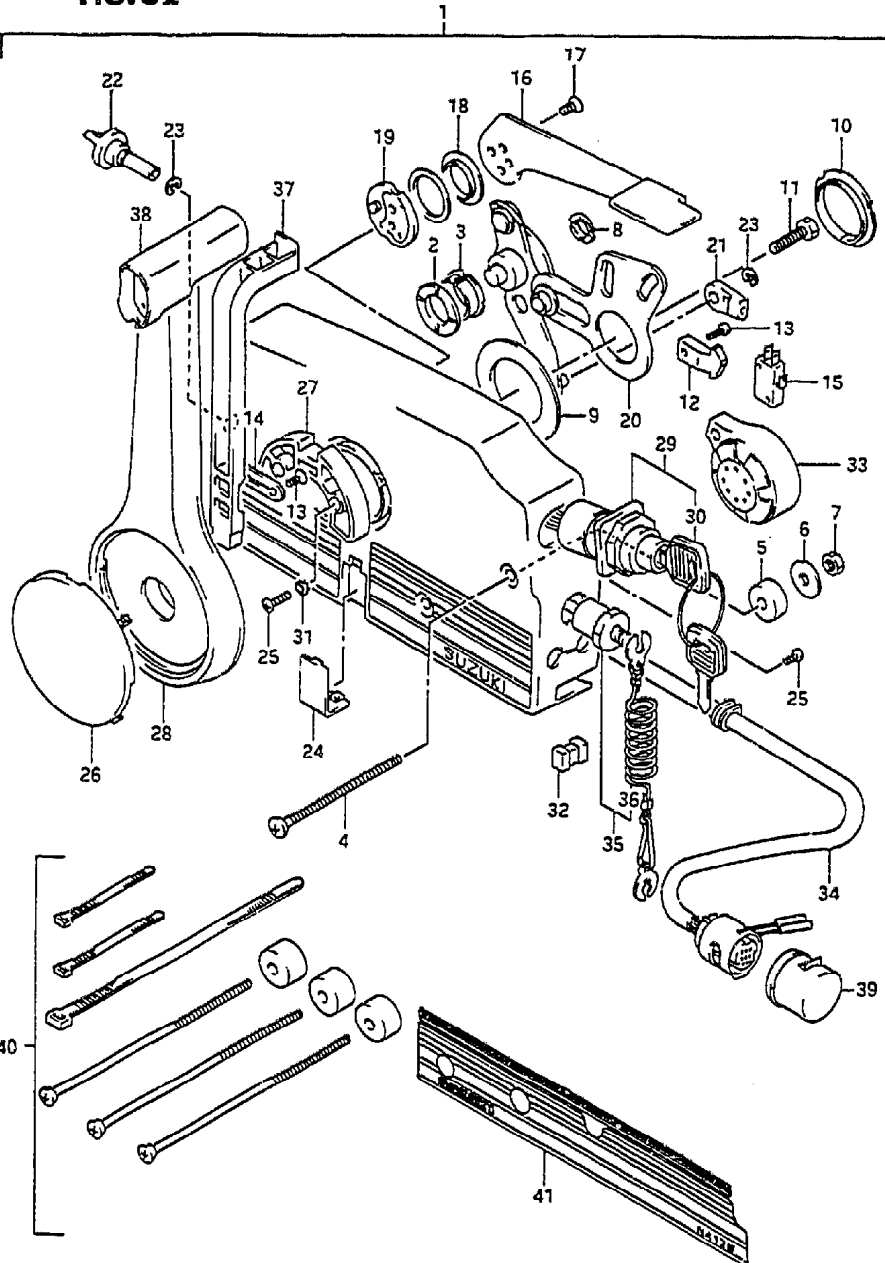

Q'TY

REF.NO.	PART NO.	DESCRIPTION	Q'TY	REMARKS
1	67200-89E12-OED	REMOTE CONTROL BOX ASSY	1	
2	67232-95600	.BUSH	1	
3	67232-95620	.BUSH	1	
4	67296-95600	.SCREW	3	
5	67294-95600	.SPACER	3	
6	09160-06104	.WASHER	3	
7	09140-06020	.NUT	3	
8	67232-95610	.BUSH	1	
9	67253-95600	.WASHER	1	
10	67252-95600	.BUSH	1	
11	09100-08232	.BOLT	1	
12	67214-95600	.ACTUATOR	1	
13	67296-94300	.SCREW	3	
14	67258-87000	.BRACKET, neutral arm	1	
15	37721-94600	.SWITCH, neutral	1	
16	67241-95680	.LEVER, free throt (Gray)	1	
17	09126-05003	.SCREW	2	
18	67243-95600	.BUSH	1	
19	67245-95600	.DRUM ASSY, free throttle	1	
20	67220-95630	.PLATE ASSY	1	
21	67275-95600	.END, cable	2	
22	67223-95600	.KNOB, brake ADJ	1	
23	67292-94300	.E RING	3	
24	67267-95610	.COVER, wire (Black)	1	
25	67296-95610	.SCREW	7	
26	67257-95610	.CAP, lever	1	
27	67256-95600	.HOLDER, neut lock	1	
28	67251-95680	.LEVER, hadle (Gray)	1	

COLOR : OED(Gray)

FIG. 32

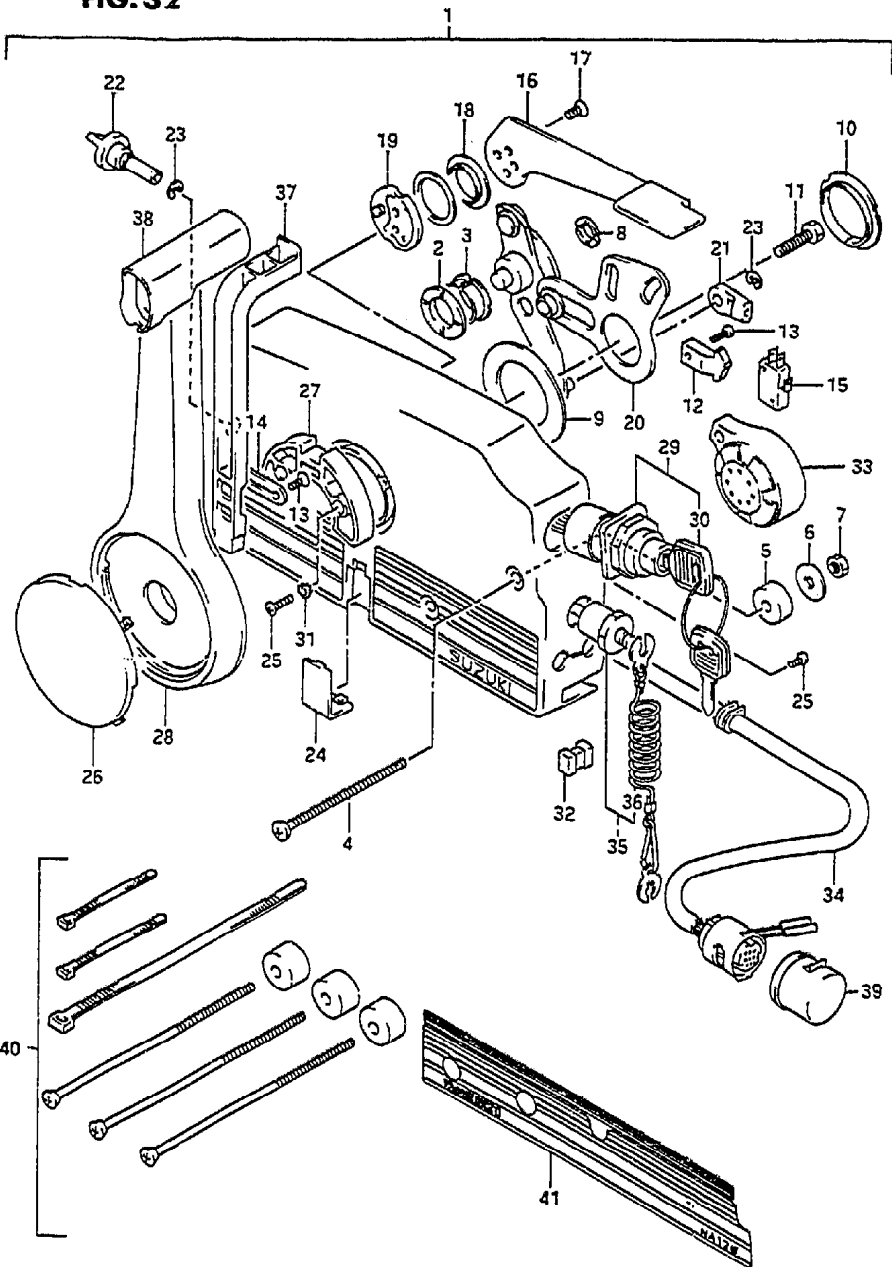
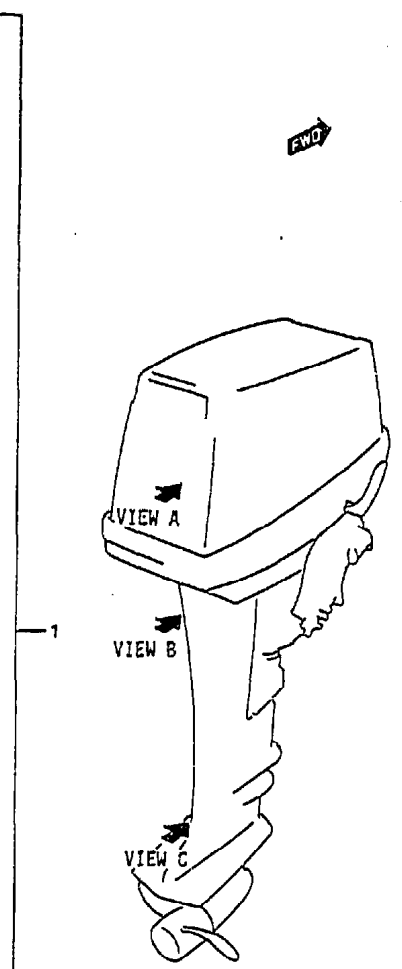
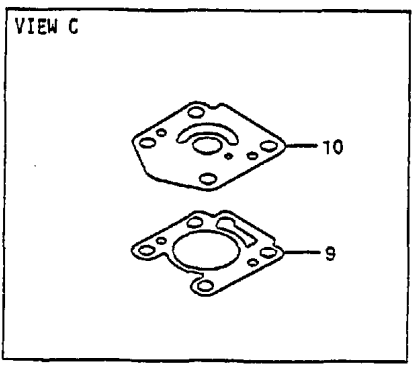
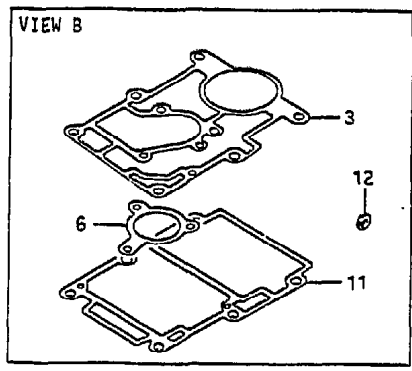
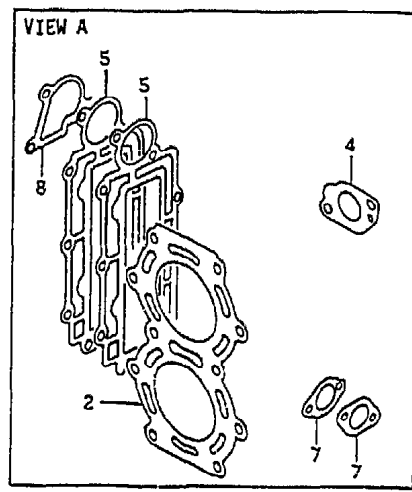

FIG.32 ( F- 8) OPT:REMOTE CONTROL (MODEL:93-97)

REF.NO.	PART NO.	DESCRIPTION	Q'TY	REMARKS
29	37110-92E01	.IGNITION SWITCH	1	
30-1	37141-92E00	..KEY (11)	1	
30-2	37141-92E10	..KEY (12)	1	
30-3	37141-92E20	..KEY (13)	1	
30-4	37141-92E30	..KEY (14)	1	
30-5	37141-92E40	..KEY (15)	1	
30-6	37141-92E50	..KEY (16)	1	
30-7	37141-92E60	..KEY (17)	1	
30-8	37141-92E70	..KEY (18)	1	
30-9	37141-92E80	..KEY (19)	1	
30-10	37141-92E90	..KEY (20)	1	
31	67297-95600	.WASHER	2	
32	67273-95600	.SPACER	1	
33	38500-92X50	.BUZZER	1	
34	36620-95D00	.WIRING HARNESS 9 WIRES	1	
35	37820-92E00	.SWITCH ASSY, emergency	1	
36	37823-92E00	..LOCK PLATE	1	
37	67255-95600	.ARM, neutral lock	1	
38	67261-95610	.GRIP	1	
39	36629-92E00	.PLUG, connector	1	
40	67140-95600	ATTACHMENT, twin remocon kit	1	OPT
41	67282-95610	DECAL, PORT (Black)	1	OPT

FIG.33

FIG.33 ( F- 9) OPT : GASKET SET



REF.NO.	PART NO.	DESCRIPTION	Q'TY	REMARKS
1	11400-89817	GASKET SET	1	
2	11141-93921	.GASKET, cylinder head	1	
3	11433-89E10	.GASKET, under oil seal HSG	1	
4	13125-91D00	.GASKET, carburetor	1	
5	14151-89E10	.GASKET, exhaust cover	2	
6	14213-89E10	.GASKET, exhaust tube	1	
7	16731-92D10	.GASKET, oil pump	2	
8	17685-89E10	.GASKET, thermost cover	1	
9	17452-93910	.GASKET, water inlet HSG	1	
10	17472-93910	.GASKET, pump case under	1	
11	52113-89E10	.GASKET, drive shaft HSG	1	
12	09161-05114	.GASKET	1	

FIG. 34

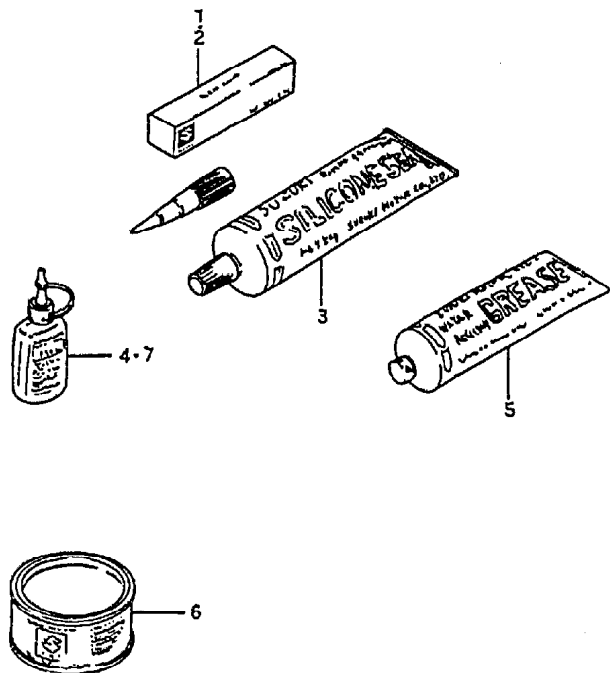

FIG.34 ( F-10) OPTIONAL

REF.NO.	PART NO.	DESCRIPTION	Q'TY	REMARKS
1	99000-31140	SUZUKI, bond N01207B	1	100g
2	93691-80030	SEAL	1	100g
3	99000-31120	SUZUKI SILICON SEAL	1	50g
4	99000-32050	THREAD LOCK CEMENT, super	1	50g
5	99000-25160	GREASE, water resistant	1	250g
6	99000-25010	SUZUKI SUPER GREASE	1	450g
7	99000-32020	THREAD LOCK CEMENT, super	1	50g, 103Q
8-1	99011-89E00-03A	MANUAL, owner's	1	model:89,not shown
8-2	99011-89E01-03A	MANUAL, owner's	1	model:90,not shown
8-3	99011-89E02-03A	MANUAL, owner's	1	model:91,not shown
8-4	99011-89E03-03A	MANUAL, owner's	1	model:92,not shown
8-5	99011-89E04-03A	MANUAL, owner's	1	model:93,not shown
8-6	99011-89E05-03A	MANUAL, owner's	1	model:94,not shown
8-7	99011-89E06-03A	MANUAL, owner's	1	model:95,not shown
8-8	99011-89E08-03A	MANUAL, owner's	1	model:96,not shown
8-9	99011-89E10-03A	MANUAL, owner's	1	model:97,not shown